

Development Kits **sysWORXX CANopen** **Chip**

Quickstart Instructions

Edition June 2020

In this manual are descriptions for copyrighted products which are not explicitly indicated as such. The absence of the trademark (©) symbol does not infer that a product is not protected. Additionally, registered patents and trademarks are similarly not expressly indicated in this manual

The information in this document has been carefully checked and is believed to be entirely reliable. However, SYS TEC electronic AG assumes no responsibility for any inaccuracies. SYS TEC electronic AG neither gives any guarantee nor accepts any liability whatsoever for consequential damages resulting from the use of this manual or its associated product. SYS TEC electronic AG reserves the right to alter the information contained herein without prior notification and accepts no responsibility for any damages which might result.

Additionally, SYS TEC electronic AG offers no guarantee nor accepts any liability for damages arising from the improper usage or improper installation of the hardware or software. SYS TEC electronic AG further reserves the right to alter the layout and/or design of the hardware without prior notification and accepts no liability for doing so.

© Copyright 2020 SYS TEC electronic AG. rights – including those of translation, reprint, broadcast, photomechanical or similar reproduction and storage or processing in computer systems, in whole or in part – are reserved. No reproduction may occur without the express written consent from SYS TEC electronic AG.

Disclaimer:

All data, information and technical specifications contained in this document has been subjected to a thorough examination. The information in the document is current at the time of publication as long as nothing else is explicitly stated. However no liability is given for the correctness, completeness and topicality of the contents.

Address:	SYS TEC electronic AG Am Windrad 2 D-08468 Heinsdorfergrund GERMANY
Ordering Information:	+49 (37 65) 38 60 00 sales@systemec-electronic.com
Technical Support:	+49 (37 65) 38 60 00 support@systemec-electronic.com
Fax:	+49 (37 65) 38 6 00 41 00
Web Site:	http://www.systemec-electronic.com

Table of Contents

1	Introduction to the Development Kits.....	1
1.1	Note for intended usage.....	1
1.2	Contents of the Development Kit sysWORXX CANopen ChipF40.....	1
1.3	Contents of the Development Kit sysWORXX CANopen Chip CoC-100 (5V).....	2
1.4	Contents of the Development Kit sysWORXX CANopen Chip CoC-100 (3.3V).....	2
1.5	Documentation	3
	Required	3
1.6	Software.....	3
2	Hardware Installation.....	5
2.1	Installing the CANopen Chip on the Developmentboard	5
2.2	Selecting the Power Supply.....	8
2.3	Physical Connection of the CAN Interface	9
2.4	Installing the USB-CANmodul1	10
2.5	Connecting the CAN Cable.....	10
3	Software installation and configuration.....	11
3.1	Installation of the USB-CANmodul driver	11
3.2	Installation of CANopen DeviceExplorer	11
3.3	Configuration of CANopen DeviceExplorer.....	11
4	Accessing to the CANopen device.....	16
4.1	Access to Digital Outputs.....	16
4.2	Reading Digital Inputs	17

List of figures

Figure 1:	Developmentboard Overview	6
Figure 2:	Suitable Developmentboard Jumper Settings	6
Figure 3:	Suitable Developmentboard I/O-Jumper Settings	7
Figure 4:	Power Connector	8
Figure 5:	Developmentboard DB-9 CAN Plug Pinout	9
Figure 6:	CAN Bus Connection Circuitry	9
Figure 7:	Window DeviceExplorer	12
Figure 8:	CAN Interface Settings	13
Figure 9:	Load EDS-File	14
Figure 10:	Set device Operational	15
Figure 11:	Write digital Input	16
Figure 12:	Read digital output	17

1 Introduction to the Development Kits

The Quickstartmanual for Development Kit sysWORXX CANopen Chip is a low-cost entry into the development of your own CANopen products and gives an overview of the possibilities and features of the CANopen software and the CAN hardware. The different Kits includes all components of a CANopen network, such as microcontroller module, the PC-to-CAN interface and a CANopen configuration tool.

System Requirements

Use of this CANopen Chip Development Kit requires:

- an PC (with Windows8/10) for use with sysWORXX USB-CANmodul1
- one free USB port for the sysWORXX USB-CANmodul1

1.1 Note for intended usage

This product is intended as a customer and application-specific test module for applications that are only used by experts in research and development facilities.

1.2 Contents of the Development Kit sysWORXX CANopen ChipF40

1x MM-217-Y	sysWORXX CANopen ChipF40
1x 4002003	Developmentboard DIPmodul (5V)
1x 3204000	sysWORXX USB-CANmodul1
1x WK045	CAN cableset
1x SV007	Power Supply 9V/500mA

1.3 Contents of the Development Kit sysWORXX CANopen Chip CoC-100 (5V)

1x	4003001	sysWORXX CANopen Chip CoC-100 (5V)
1x	4002003	Developmentboard DIPmodul (5V)
1x	3204000	sysWORXX USB-CANmodul1
1x	WK045	CAN cableset
1x	SV007	Power Supply 9V/500mA

1.4 Contents of the Development Kit sysWORXX CANopen Chip CoC-100 (3.3V)

1x	4003002	sysWORXX CANopen Chip CoC-100 (3.3V)
1x	4002026	Developmentboard DIPmodul (3.3V)
1x	3204000	sysWORXX USB-CANmodul1
1x	WK045	CAN cableset
1x	SV007	Power Supply 9V/500mA

1.5 Documentation

The following table lists all manuals relevant for the CANopen Chip. These can be found on the corresponding product website.

L-1151	QuickStart Manual Development Kit sysWORXX CANopen Chip (this document)
L-1000	Hardware Manual Developmentboard sysWORXX CANopen Chip
L-1062	System Manual sysWORXX CANopen Chip F40
L-2365	System Manual sysWORXX CANopen Chip CoC-100
L-487	Manual sysWORXX USB-CANmodul1

1.6 Required Software

All documents and software can be found on the corresponding product website.

SO-1057	sysWORXX CANopen Chip F40, <i>.eds</i> and <i>.bmp</i> files
SO-1134	sysWORXX CANopen Chip CoC-100, <i>.eds</i> files
SO-1124	sysWORXX CANopen DeviceExplorer, evaluation version
SO-387	sysWORXX USB-CANmodul drivers and tools

2 Hardware Installation

Note: Modifications to the hardware configuration and cables should only be carried out while all devices are powered off!

2.1 Installing the CANopen Chip on the Developmentboard

Before installing the CANopen Chip on the Developmentboard, check the configuration of dip-switch on the top side of the CANopen Chip. The dips 1..8 must be on position OFF. This configuration results in the following:

- a NodeID of 40h
- a bitrate of 125kBit/s (refer to CANopen Chip System-Manual, L-1062).
- the I/O configuration 0 (see L-1062 for more information; **only this configuration can be used on the Developmentboard**)

If the CANopen Chip is not already pre-installed, mount it pins-down onto the Developmentboard's receptacle footprint (X101) for DIPmodules as shown in *Figure 1* below. Ensure that pin 1 on the module matches pin 1 of the receptacle on the Developmentboard.

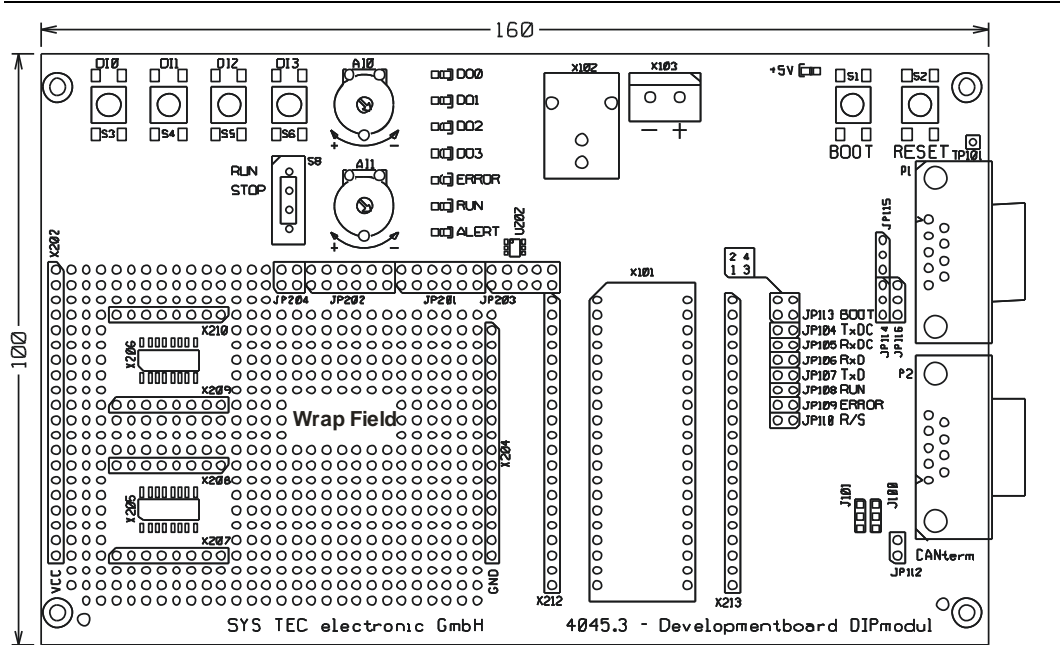

Figure 1: Developmentboard Overview

Configure the Jumpers on the Developmentboard as indicated below. This correctly routes the CAN signals to the DB-9 connector (P2) and connects the onboard peripheral devices to the CANopen TChip

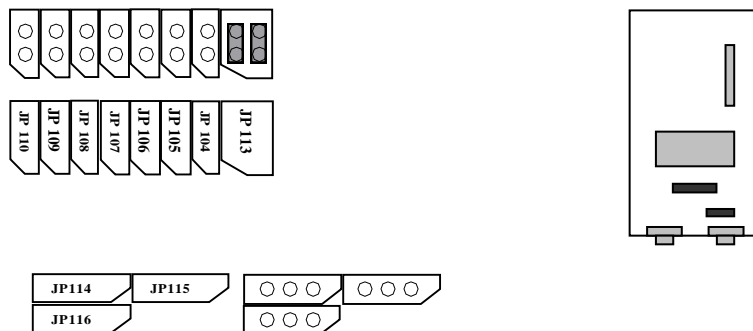

Figure 2: Suitable Developmentboard Jumper Settings

The Jumpers JP201 ... JP204 have the following settings:

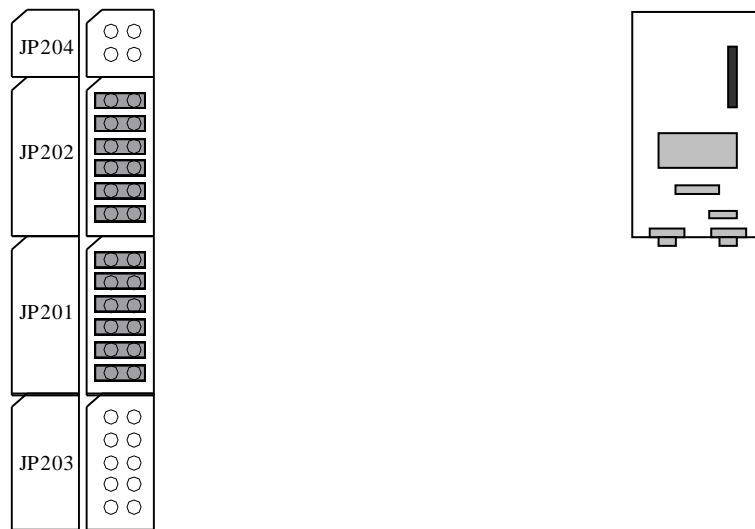

Figure 3: Suitable Developmentboard I/O-Jumper Settings

2.2 Selecting the Power Supply

There are two ways to connect a power supply to the Developmentboard:

- Connection via the low voltage socket at (8 - 13VDC), X102
- Connection via the low voltage terminal block (8 - 13VDC), X103

Note: Please avoid changing jumpers or modules while the Developmentboard is powered on!

Connection via the Low Voltage Socket X102

An unregulated power supply ranging from 8V to 13V can be connected to the Developmentboard at low voltage socket X102.

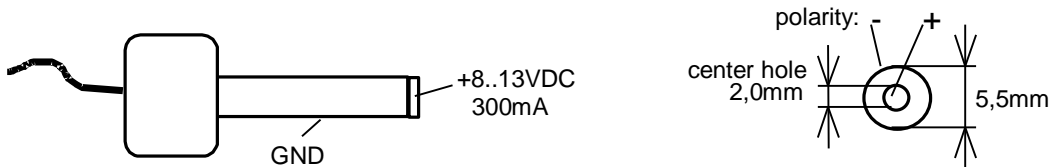

Figure 4: Power Connector

Connection via the Low Voltage Terminal Block X103

The low voltage terminal block is located next to the voltage socket at X102.

Ensure that the correct polarity is applied to the terminal block. The GND-Connection is near X102.

The configuration of the Developmentboard is now complete.

2.3 Physical Connection of the CAN Interface

The Developmentboard provides a DB-9 connector for the physical CAN bus connection. The pin definition for the CAN plug P2 is shown in the table below:

Pin	Pin description
2	CAN_L (dominant low)
3	CAN_GND
7	CAN_H (dominant high)

Figure 5: Developmentboard DB-9 CAN Plug Pinout

The CAN bus cable can be either a twisted pair or a ribbon cable. The wave resistance of the cable should be 120 Ohm. A 120 Ohm termination resistor has to be connected to the cable between CAN_H and CAN_L at both ends of the bus cable (see chapt. 0). The Jumper JP112 on the Developmentboard must be open.

The next figure shows the general CAN bus connection circuitry.

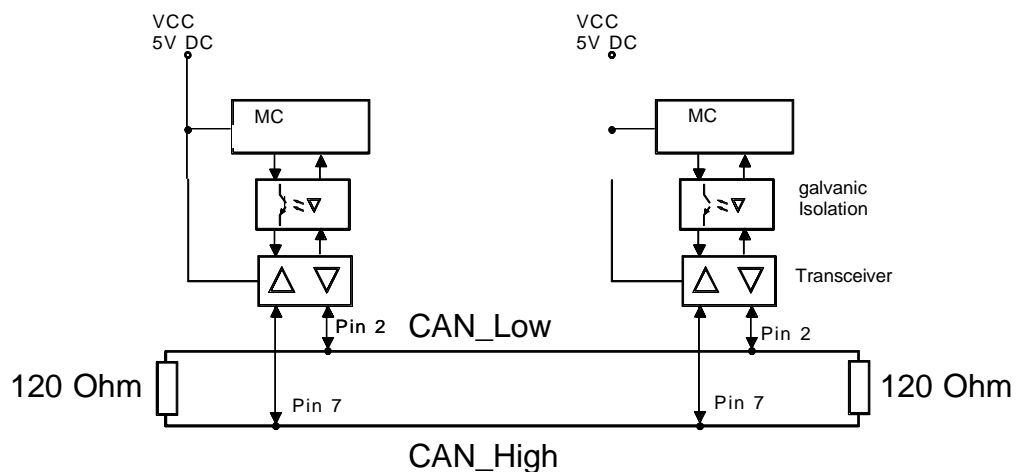

Figure 6: CAN Bus Connection Circuitry

2.4 Installing the USB-CANmodul1

Note: Install the software before connecting the USB-CANmodul to the host-PC.
For software installation see chapter 0.

For more information, see the manual L-487. You can find the manual on the product website of the USB-CANmodul1.

2.5 Connecting the CAN Cable

The CANopen Chip Development Kit includes the cable set WK054. This set contains a 10 foot 9-pin ribbon cable with 5 DB-9 sockets and 2 DB-9 plugs with 120 Ohm termination resistors.

This cable set is intended for rapid setup and demonstration purposes only. For continuous operation use of a CAN cable as described in section 2.3 *Physical Connection* is recommended.

Connect the DB-9 plugs with the built in 120 Ohm termination resistors to each end of the CAN cable. Connect the remaining DB-9 sockets of the cable to the Developmentboard and the PC to CAN interface.

All hardware components of the Development Kit should now be properly configured and connected to the CAN bus cable. You are now ready to turn on the power supply to the Developmentboard.

3 Software installation and configuration

The needed software is listed in section 1.6.

3.1 Installation of the USB-CANmodul driver

Note: Install the software before connecting the USB-CANmodul to the host-PC. Installation under Windows might require to have administrator rights during the installation process!

Installation and operation of the USB-CANmodul requires a host-PC with a USB port that is running Microsoft Windows 7, 8, 8.1 or 10.

- a) Download the Utility Disk from the product website.
- b) Unpack the archive and start the *SO-387.exe*.
- c) Follow the setup instructions to install the software.

Note: You will need to restart your PC at the end of the installation procedure.

Make sure that the PC has finished boot before connecting the USB-CANmodul.

3.2 Installation of CANopen DeviceExplorer

- a) Download the DeviceExplorer from the product website.
- b) Unpack the archive and start the *SO-1124.exe*.
- c) Follow the setup instructions to install the software

3.3 Configuration of CANopen DeviceExplorer

Start the CANopen DeviceExplorer Demo by selecting the shortcut from the desktop or quickbar.

The CANopen DeviceExplorer Demo main window will now appear:

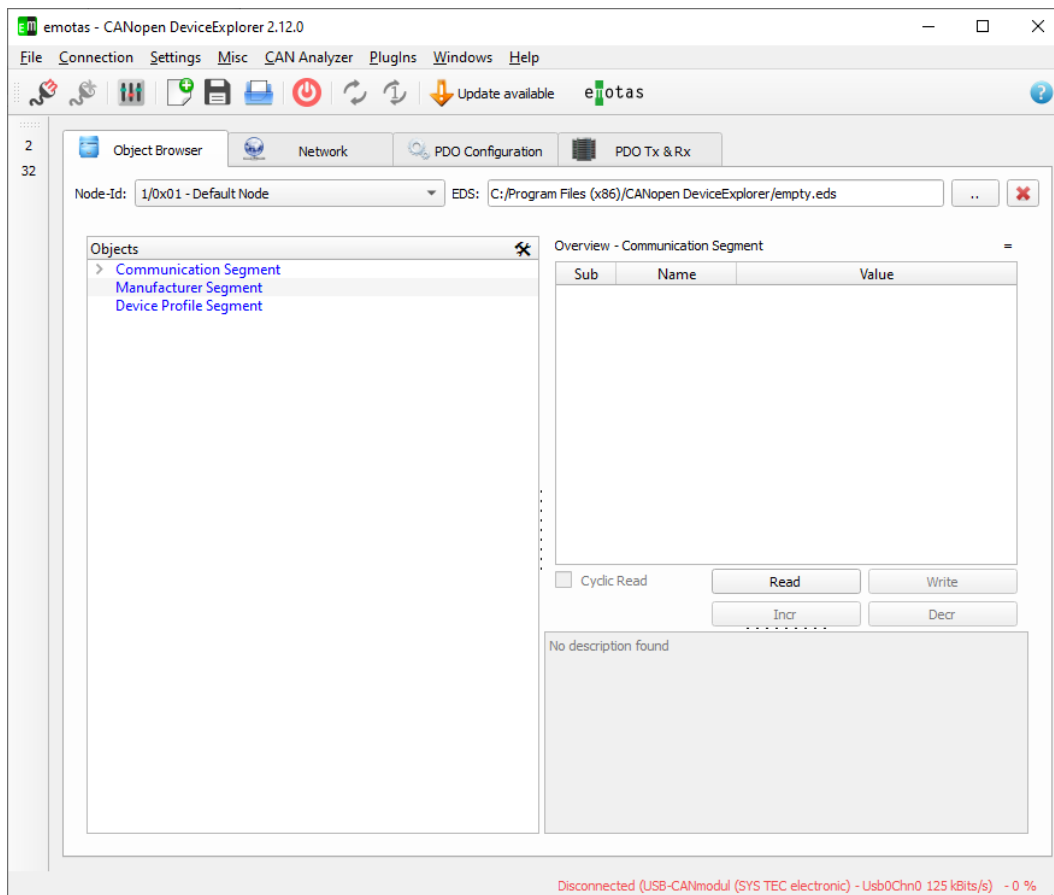

Figure 7: Window DeviceExplorer

Before accessing the device, please verify the settings for hardware environment in the menu *Connection – CAN Interface Settings*. Please make the following settings:

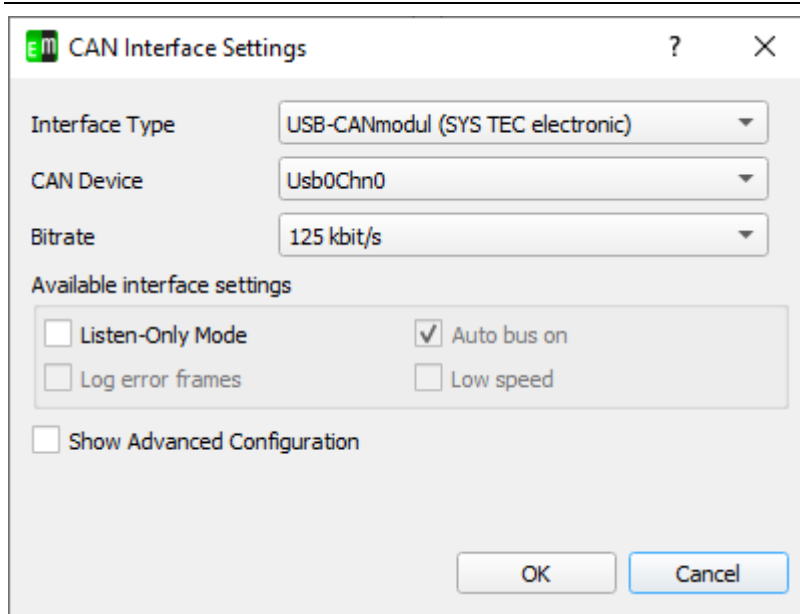

Figure 8: CAN Interface Settings

As Interface Type, the USB-CANmodul must be selected and the baudrate of 125kBit/s has to be used. Now acknowledge the settings by selecting *OK*.

Additionally the Node-Id has to match the number, the CANopen-Chip is using. This depends on the used configuration of the dip-switch (see section 2.1).

Now the EDS-File for CANopen Chip must be selected, before an access to the device is possible. To load an EDS-File, select the “...” button next to the EDS-Filepath and select the downloaded EDS-File:

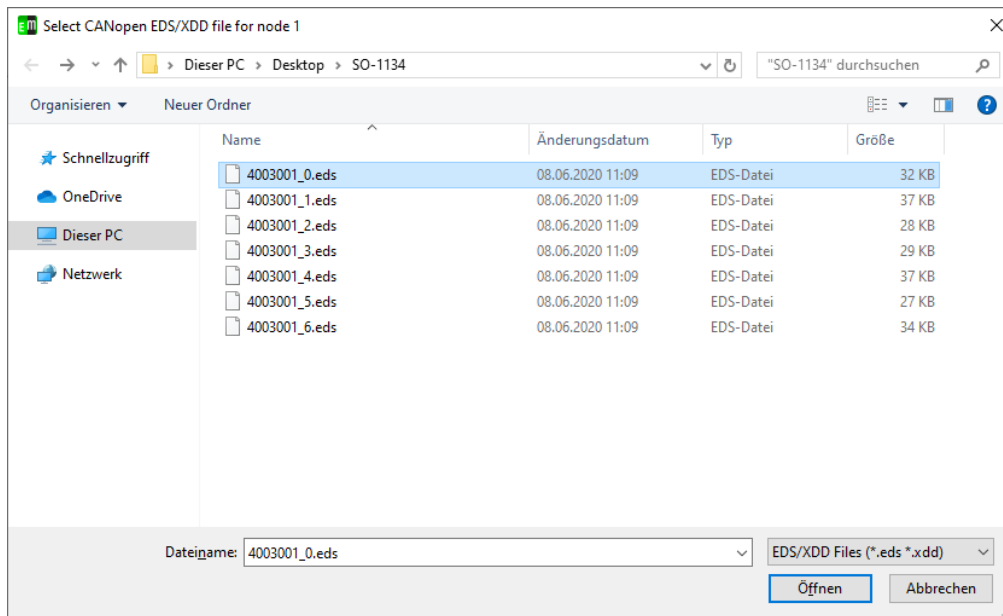



Figure 9: Load EDS-File

As mentioned earlier, only the configuration 0 can be used with the Developmentboard, so the EDS-File with 0 at the end has to be selected.

- To establish a connection to the CANopen Chip click on the connect-button  or select *connect* in menu *Connection*
- On the Tab *Network* set the device to state *Operational* by selecting *Start Node*.

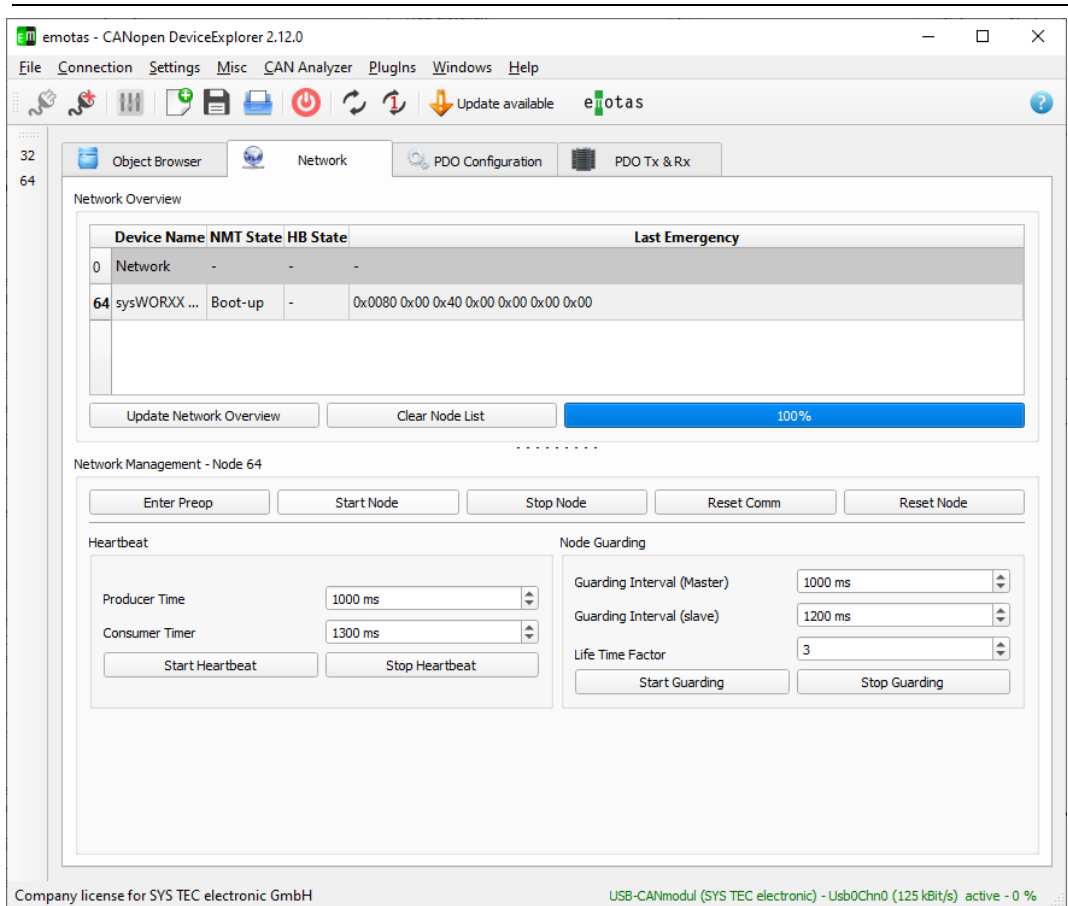

Figure 10: Set device Operational

Now the access to the CANopen Chip is established. In the next chapter the access to the Object Dictionary is described.

4 Accessing to the CANopen device

The IOs of the CANopen Chip are accessed via the Object Dictionary Entries using the DeviceExplorer.

4.1 Access to Digital Outputs

In order to set an output from within the CANopen DeviceExplorer Demo, it is necessary to navigate through the Object Dictionary (OD) structure.

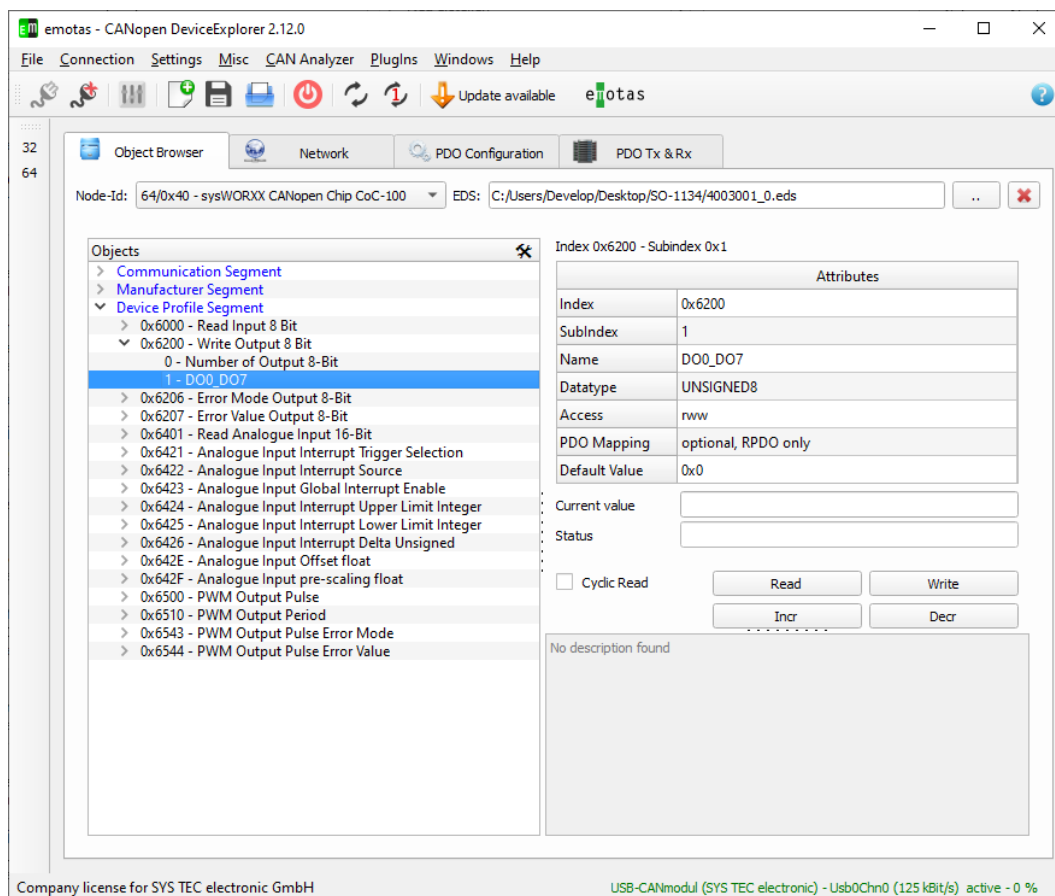

Figure 11: Write digital Input

Digital outputs are accessed via the entry *6200 Write Output 8Bit*. The LEDs DO0...DO3 on the Developmentboard can be accessed in the subindex *6200,1 Digital Output*. In the right window it is then

possible to assign HEX values to the four possible outputs and to subsequently send these values to the CANopen Chip via the *Write* button. As an example, a value of 0x5 could be written to the device and so the LEDs DO0 and DO2 would then be addressed and illuminate.

4.2 Reading Digital Inputs

The CANopen DeviceExplorer can also be used to read inputs on the CANopen Chip. The procedure is similar to the write access of outputs.

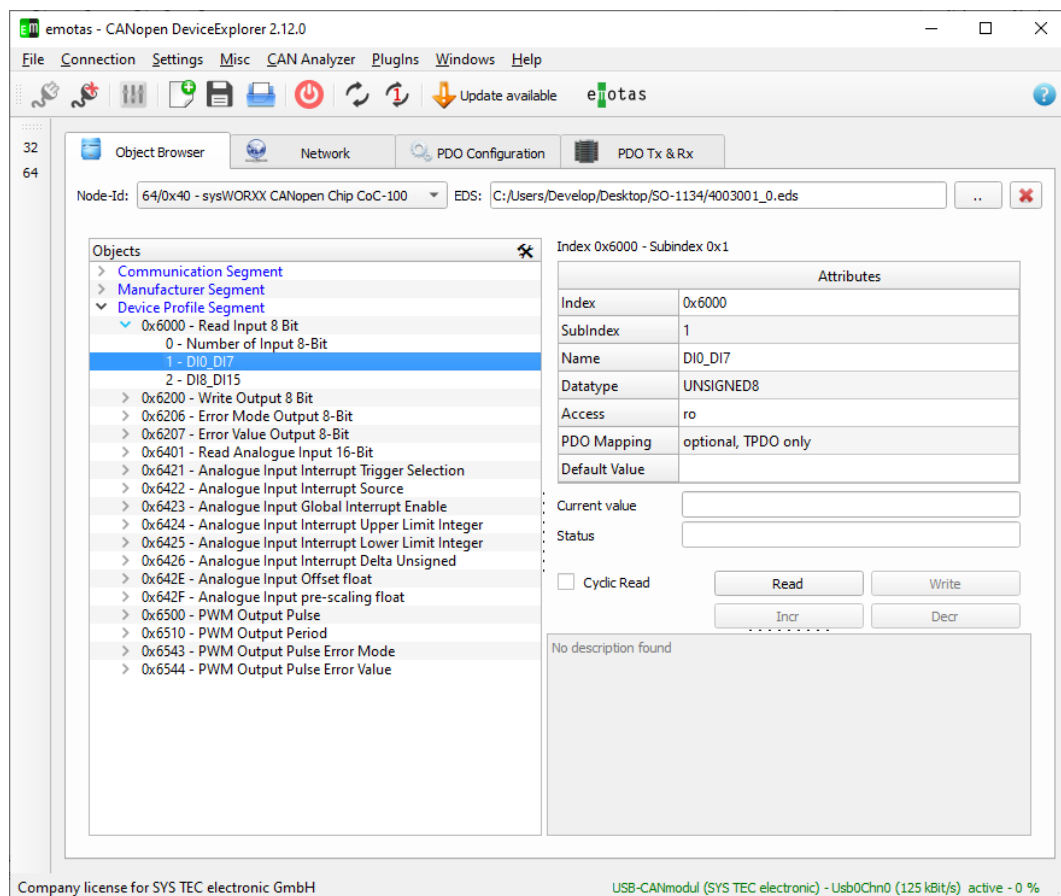

Figure 12: Read digital output

Digital inputs can be accessed via the entry *6000 Read Input 8Bit*. In the subindex *6000,1 DI0_DI7* it is possible to read the state of push buttons DI0...DI3. The current input values appear in the right

window after the *Read* – button has been pushed. If, for example, one of the four push buttons on the Developmentboard has been pushed during the *Read* – Button is pressed, the adjusted value appears in the right window.

Document: Development Kits sysWORXX CANopen
Chip
Document number: L-1151e_2, Edition June 2020

How would you improve this manual?

Did you find any mistakes in this manual? page

Submitted by:

Customer number: _____

Name: _____

Company: _____

Address: _____

Return to: SYS TEC electronic AG
Am Windrad 2
D-08468 Heinsdorfergrund
GERMANY
Fax : +49 (0) 37 65 / 38 60 00

Published by

© SYS TEC AG GmbH 2020

SYS TEC
ELECTRONIC
Ordering No. L-1151e_2
Printed in Germany