

# CANopen $\mu$ Chip – Fact sheet

## Overview

The CANopen  $\mu$ Chip is a tiny yet cost effective single Chip CANopen IO. The CANopen  $\mu$ Chip features various IO configurations including digital and analogue inputs and outputs.

All inputs and outputs are accessible via the CANopen protocol, which is implemented in the pre-programmed firmware of the module. Thus the CANopen  $\mu$ Chip can be used in a wide field of application.

The CANopen  $\mu$ Chip implements a CANopen slave device according CANopen device profile **DS401** and CANopen communication profile **DS301 V4.02**.

Two LED-ports indicate the device state according to **DR-303-3 V1.0**.

## CANopen features:

- Communication profile according to CiA standard DS301 in version V4.02
- Device profile according to CiA standard DSP401
- State indicators according to CiA standard DR-303-3 V1.0
- Layer Setting Service (LSS) according to CiA standard DSP305
- 4 TPDO and 4 RPDO
- Dynamic PDO-Linking and -Mapping
- 2 SDO-Server
- Life guarding, Node guarding, Heartbeat
- 5 Heartbeat Consumers
- Emergency Producer
- Minimum Boot Up capability
- Manufacturer extension for usage as NMT-boot master

## predefined Pins for Chip-configuration

### 4 bit Node ID:

Allows for configuration of node ID from 40H ... 4EH

The node ID is derived from the pin setting by:

$40H + 1 * DIP1 + 2 * DIP2 + 4 * DIP3 + 8 * DIP4$

Setting the value 0xF causes a reset to factory settings when the modules get reset. The full range of node ID is configurable via LSS only.

## Device specification:

- Operating voltage:  $5V \pm 10\%$
- Current consumption: typically 30mA
- storage of configuration data on Non-volatile memory (provided by customer)
- predefined pins for easy configuration of node ID, baud rate and IO configuration (e.g. by a DIP-switch)
- Seven different IO configurations on 28 IO pins, selectable via portpins and Object Dictionary
- Digital outputs:  
GND < L-level < 0.4V  
4.5V < H-level < VCC
- Digital inputs:  
GND - 0.3V < L-level < 0.8V  
0.8 • VCC < H-level < VCC + 0.3V
- Analogue inputs:  
Input voltage: VAGND ... VREF  
Logical resolution: 15-bit signed (OD value)  
Physical resolution: 10-bit (see manual)  
Input capacity: 10.7pF  
Reference voltage: +2.7V ... VCC
- PWM outputs:  
See digital outputs for details  
PWM frequency: max. 21kHz (CAN>10kBit)  
PWM frequency: max. 11,5kHz (CAN=10kBit)
- CAN-bus baud rate: 10kBit/s to 1Mbit/s
- Operating temperature: -40°C to +85°C
- Storage temperature: -40°C to +90°C
- Package: 64-pin Plastic LQFP

### 2 bit Baud rate:

Selectable via pins: 0 = 125kBit/s  
1 = 20kBit/s  
2 = 500kBit/s  
3 = 1000kBit/s

The full range of baud rate is configurable via LSS only.

### 2 bit IO configuration:

Selectable via pins is IO configuration 0 to 3.

Additionally all IO configurations are selectable via OD entry on index 2000H in manufacturer specific section.

### Device pinout and IO configurations

Pin	0	1	2	3	4	5	6
1	VAGND ground signal for reference voltage						
2	VREF reference voltage des AD-Wandlers						
3	DI 0	AI 2	DI 2	DI 2	AI 2	DI 2	AI 2
4	DI 1	AI 3	DI 3	DI 3	AI 3	DI 3	AI 3
5	DI 2	AI 4	DI 4	DI 4	AI 4	DI 4	DI 2
6	DI 3	AI 5	DI 5	DI 5	AI 5	DI 5	DI 3
7	DI 4	AI 6	DI 6	DI 6	AI 6	DI 6	DI 4
8	DI 13	AI 7	DI 7	DI 7	AI 7	DI 7	DI 5
9	DI 12	DO 4	DO 4	DO 4	DI 8	DI 16	DI 14
10	DI 11	DO 5	DO 5	DO 5	DI 9	DI 17	DI 15
11	DI 6	DO 6	DO 6	DO 6	DI 10	DI 18	DO 2
12	DI 5	DO 7	DO 7	DO 7	DI 11	DI 19	DO 3
13	MRST EEPROM						
14	MTRSR EEPROM						
15	SCLK EEPROM						
16	RxDc receive signal of internal CAN-controllers, TTL-level						
17	TxDc transmit signal of internal CAN-controllers, TTL-level						
18	GND ground signal for VCC						
19	reserved						
20	reserved						
21	MD2						
22	MD1						
23	MD0						
24	nc						
25	nc						
26	reserved						
27	reserved						
28	pin 0 for node ID						
29	pin 1 for node ID						
30	pin 2 for node ID						
31	pin 3 for node ID						
32	CS EEPROM						
33	reserved						
34	DO 4	DO 0	DO 0	DO 0	DI 12	DI 20	DI 0
35	DO 5	DO 1	DO 1	DO 1	DI 13	DI 21	DI 1
36	pin 0 for baudrate						
37	pin 1 for baudrate						
38	pin 0 for IO configuration						
39	pin 1 for IO configuration						
40	PWM 0	PWM 0	PWM 0	PWM 0	PWM 0	PWM 0	PWM 0
41	PWM 1	PWM 1	PWM 1	PWM 1	PWM 1	PWM 1	PWM 1
42	PWM 2	PWM 2	PWM 2	PWM 2	PWM 2	PWM 2	PWM 2
43	PWM 3	PWM 3	PWM 3	PWM 3	PWM 3	PWM 3	PWM 3
44	LED green						
45	/RESET Reset input						
46	XTAL1						
47	XTAL2						
48	GND ground signal for VCC						
49	VCC power supply, +5VDC						
50	C						
51	LED red						
52	DO 6	DO 2	DO 2	DO 2	DI 14	DI 22	DO 0
53	DO 7	DO 3	DO 3	DO 3	DI 15	DI 23	DO 1
54	DI 10	DI 0	DI 8	DO 8	DI 0	DI 8	DI 6
55	DI 9	DI 1	DI 9	DO 9	DI 1	DI 9	DI 7
56	DI 8	DI 2	DI 10	DO 10	DI 2	DI 10	DI 8
57	DI 7	DI 3	DI 11	DO 11	DI 3	DI 11	DI 9
58	DO 3	DI 4	DI 12	DO 12	DI 4	DI 12	DI 10
59	DO 2	DI 5	DI 13	DO 13	DI 5	DI 13	DI 11
60	DO 1	DI 6	DI 14	DO 14	DI 6	DI 14	DI 12
61	DO 0	DI 7	DI 15	DO 15	DI 7	DI 15	DI 13
62	AI 0	AI 0	DI 0	DI 0	AI 0	DI 0	AI 0
63	AI 1	AI 1	DI 1	DI 1	AI 1	DI 1	AI 1
64	AVCC power supply, +5VDC						

Configuration	DI	DO	AI	PWM
0	14	8	2	4
1	8	8	8	4
2	16	8	-	4
3	8	16	-	4
4	16	-	8	4
5	24	-	-	4
6	16	4	4	4

DI	Digital Input
DO	Digital Output
AI	Analogue Input
PWM	PWM Output

### PDO Mapping

The following table show the default PDO-mapping of the CANopen ChipF40 for each IO configuration. Due to the different IO signals available, the available PDO depends on IO configuration. Thus, some PDO might be set invalid if not used. The PDO-mapping and linking can be changed dynamically by use of a standard CANopen configuration tool. The configuration can be saved to non-volatile memory and thus is available after restart.

	ID	Length	BYTE 0	BYTE 1	BYTE 2	BYTE 3	BYTE 4	BYTE 5	BYTE 6	BYTE 7	
<b>configuration 0</b>											
1. RPDO	200H+Node ID	1	DO0_7								
3. RPDO	400H+Node ID	8	Pulse PWM0 6500H/1		Pulse PWM1 6500H/2		Pulse PWM2 6500H/3		Pulse PWM3 6500H/4		
1. TPDO	180H+Node ID	2	DI0_7	DI8_15							
2. TPDO	280H+Node ID	4	AI0 6401H/1		AI1 6401H/2						

<b>configuration 1</b>											
1. RPDO	200H+Node ID	1	DO0_7								
3. RPDO	400H+Node ID	8	Pulse PWM0 6500H/1		Pulse PWM1 6500H/2		Pulse PWM2 6500H/3		Pulse PWM3 6500H/4		
1. TPDO	180H+Node ID	1	DI0_7								
2. TPDO	280H+Node ID	8	AI0	AI1	AI2	AI3					
3. TPDO	380H+Node ID	8	AI4	AI5	AI6	AI7	AI8				

<b>configuration 2</b>											
1. RPDO	200H+Node ID	1	DO0_7								
3. RPDO	400H+Node ID	8	Pulse PWM0 6500H/1		Pulse PWM1 6500H/2		Pulse PWM2 6500H/3		Pulse PWM3 6500H/4		
1. TPDO	180H+Node ID	2	DI0_7	DI8_15							

<b>configuration 3</b>											
1. RPDO	200H+Node ID	2	DO0_7	DO8_15							
3. RPDO	400H+Node ID	8	Pulse PWM0 6500H/1		Pulse PWM1 6500H/2		Pulse PWM2 6500H/3		Pulse PWM3 6500H/4		
1. TPDO	180H+Node ID	1	DI0_7								

<b>Konfiguration 4</b>										
3. RPDO	400H+Node ID	8	Pulse PWM0 6500H/1		Pulse PWM1 6500H/2		Pulse PWM2 6500H/3		Pulse PWM3 6500H/4	
1. TPDO	180H+Node ID	2	DI0_7	DI8_15						
2. TPDO	280H+Node ID	8	AI0	AI1	AI2	AI3				
3. TPDO	380H+Node ID	8	AI4	AI5	AI6	AI7	AI8			

<b>configuration 5</b>										
3. RPDO	400H+Node ID	8	Pulse PWM0 6500H/1		Pulse PWM1 6500H/2		Pulse PWM2 6500H/3		Pulse PWM3 6500H/4	
1. TPDO	180H+Node ID	3	DI0_7	DI8_15	DI16_23					

<b>configuration 6</b>											
1. RPDO	200H+Node ID	1	DO0_7								
3. RPDO	400H+Node ID	8	Pulse PWM0 6500H/1		Pulse PWM1 6500H/2		Pulse PWM2 6500H/3		Pulse PWM3 6500H/4		
1. TPDO	180H+Node ID	2	DI0_7	DI8_15							
2. TPDO	280H+Node ID	8	AI0	AI1	AI2	AI3					

## Object Dictionary

Index	Object	Name	Data type	Object is mappable	Object gets saved via 1010H	Object gets Restored via 1011H
1000H	Var	Device type number	Unsigned32	-	-	-
1001H	Var	Error Register	Unsigned8	-	-	-
1003H	Array	Error Meldung	Unsigned32	-	auto	w 0 auf Sub0
1005H	Var	Identifier SYNC-Message	Unsigned32	-	x	x
1007H	Var	SYNC window length	Unsigned32	-	x	x
1008H	Var	Device description	String	-	-	-
1009H	Var	Hardware Version	String	-	-	-
100AH	Var	Software Version	String	-	-	-
100CH	Var	Guard Time	Unsigned16	-	x	x
100DH	Var	Life Time Factor	Unsigned8	-	x	x
1010H	Array	User-Parameter save	Unsigned32	-	-	-
1011H	Array	Default-Parameter reload	Unsigned32	-	-	-
1014H	Var	Identifier Emergency	Unsigned32	-	x	x
1016H	Array	Consumer Heartbeat Time	Unsigned32	-	x	x
1017H	Var	Producer Heartbeat Time	Unsigned16	-	x	x
1018H	Record	Identity Object	Identity	-	-	-
1029H	Array	Error Behaviour	Unsigned8	-	x	x
1200H	Record	1 <sup>st</sup> Server SDO Parameter	SDO Parameter	-	-	-
1201H	Record	2 <sup>nd</sup> Server SDO Parameter	SDO Parameter	-	x	x
1400H	Record	RPDO1 Communication parameter	PDOComPar	-	x	x
1401H	Record	RPDO2 Communication parameter	PDOComPar	-	x	x
1402H	Record	RPDO3 Communication parameter	PDOComPar	-	x	x
1403H	Record	RPDO4 Communication parameter	PDOComPar	-	x	x
1600H	Record	RPDO1 Mapping parameter	PDOMapping	-	x	x
1601H	Record	RPDO2 Mapping parameter	PDOMapping	-	x	x
1602H	Record	RPDO3 Mapping parameter	PDOMapping	-	x	x
1603H	Record	RPDO4 Mapping parameter	PDOMapping	-	x	x
1800H	Record	TPDO1 Communication parameter	PDOComPar	-	x	x
1801H	Record	TPDO2 Communication parameter	PDOComPar	-	x	x
1802H	Record	TPDO3 Communication parameter	PDOComPar	-	x	x
1803H	Record	TPDO4 Communication parameter	PDOComPar	-	x	x
1A00H	Record	TPD01 Mapping parameter	PDOMapping	-	x	x
1A01H	Record	TPD02 Mapping parameter	PDOMapping	-	x	x
1A02H	Record	TPD03 Mapping parameter	PDOMapping	-	x	x
1A03H	Record	TPD04 Mapping parameter	PDOMapping	-	x	x
2000H	Var	I/O Configuration	Unsigned8	-	auto Zugriff	DIP 0FH
2001H	Var	NMT-Boot-Configuration	Unsigned8	-	auto Zugriff	DIP 0FH
6000H	Array	PDO Digital Input <sup>1</sup>	Unsigned8	x	-	-
6200H	Array	PDO Digital Output <sup>1</sup>	Unsigned8	x	-	-
6206H	Array	Error Mode Digital Output <sup>1</sup>	Unsigned8	-	x	x
6207H	Array	Error State Digital Output <sup>1</sup>	Unsigned8	-	x	x
6401H	Record	PDO Analog Input <sup>1</sup>	Integer16	x	-	-
6421H	Array	Interrupt Trigger Selection <sup>1</sup>	Unsigned8	-	x	x
6422H	Array	Interrupt Source <sup>1</sup>	Unsigned32	x	-	-
6423H	Var	Global Interrupt Enable <sup>1</sup>	Boolean	-	x	x
6424H	Array	Interrupt upper Limit <sup>1</sup>	Integer32	-	x	x
6425H	Array	Interrupt lower Limit <sup>1</sup>	Integer32	-	x	x
6426H	Record	Input Interrupt Delta <sup>1</sup>	Unsigned32	-	x	x
6500H	Array	PWM Pulse	Unsigned16	x	-	-
6510H	Array	PWM Period	Unsigned16	x	x	x
6543H	Array	PWM Output Error Mode	Unsigned8	-	x	x
6544H	Array	PWM Output Error Value	Unsigned16	-	x	x

<sup>1</sup> Availability of this object depends on IO configuration selected

## Sample schematics:

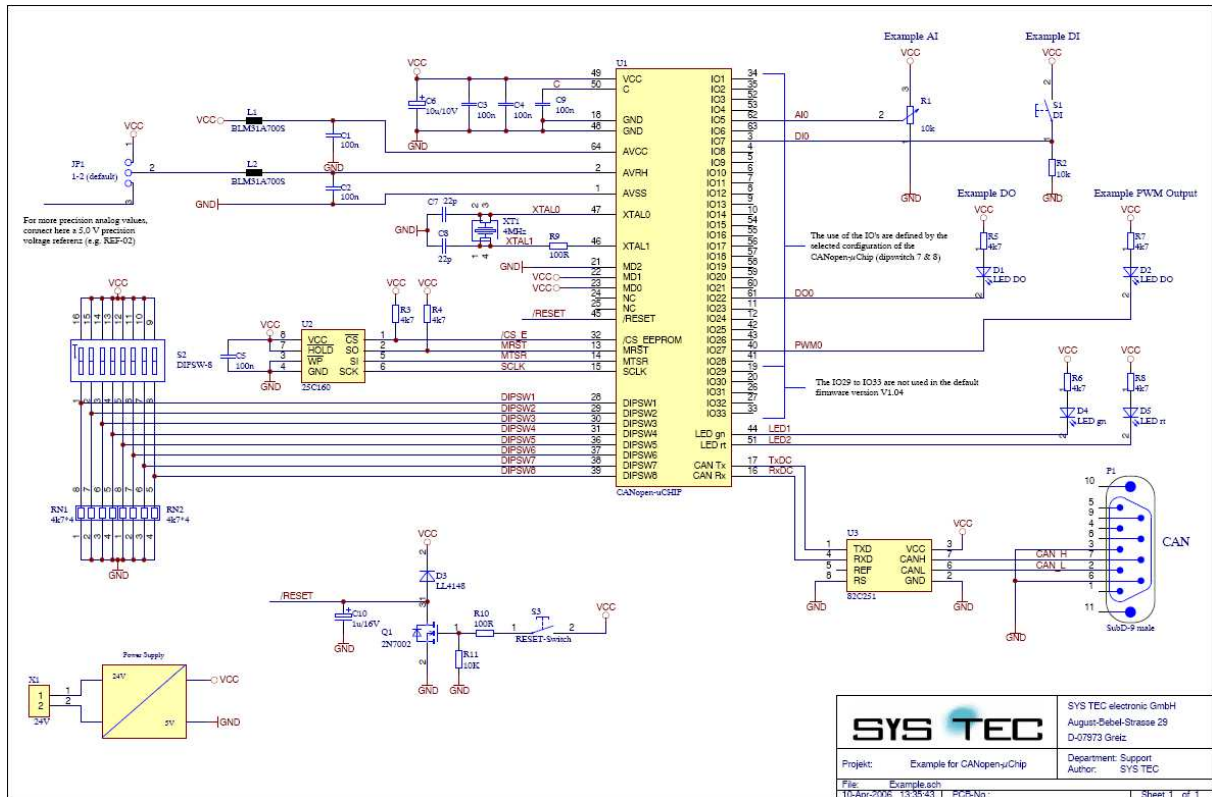

### Important!

All inputs not used needs to drawn to a defined signal such as GND to avoid any flicker on these inputs and the unwanted transmission of PDO.

### Delivery contents / order number

Manual and corresponding EDS-file.

3301001      CANopen µChip

### Also available:

MM-215-Y      CANopen Chip164  
 MM-217-Y      CANopen ChipF40  
 MM-217-V3Y    CANopen ChipF40 compatible to  
 MM-215-Y

4002003      Developmentboard for CANopen ChipF40

KMM-217-Y      Development Kit CANopen ChipF40