

CANopen IO–X5 – Fact sheet

Overview

The CANopen IO–X5 is a very compact and cost effective CANopen IO module featuring a high-density of industrial proven IO's.

The module includes a CPU-core including the pre-programmed firmware for CANopen communication and peripherals for the industrial inputs and outputs. Extensive diagnostic routines are implemented to ensure a most reliable and safe operation.

All inputs and outputs as well as configuration parameters are accessible via the CANopen protocol. The CANopen IO–X5 is a CANopen slave device according CANopen device profile **CiA 404 DS V1.2** and CANopen communication profile **CiA 301 DS V4.02**. Two LED indicate the device state according to **CiA 303-3 DR V1.0**.

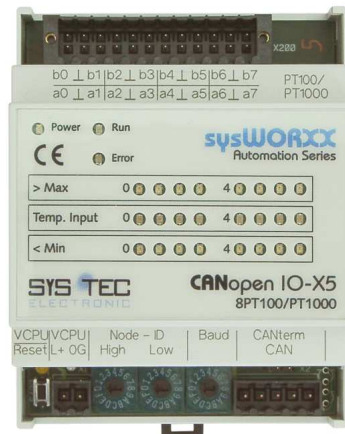

IO configuration:

- 8 RTD input channels
each configurable as PT100 or PT1000 input type
3-wire connection points
Resolution 12bit (optional 14bit)
Accuracy < 0.5% at 12bit resolution
Automatic self-calibration of ADC

CANopen features:

- Communication profile CiA 301 DS V4.02
- Device profile CiA 404 DS V1.2
- State indicator profile CiA 303-3 DR V1.0
- Layer Setting Service (LSS)
CiA 305 DS V1.0
- 4 TPDO
- Dynamic PDO-Linking and –Mapping
- SDO-Server
- Life guarding, Node guarding, Heartbeat Producer
- Emergency Producer
- Minimum Boot-up capability (Slave)
- Minimum NMT boot-up master (Manufacturer extension)

Communication and device configuration:

- Galvanic decoupled CAN-bus driver supports up to 110 CAN-nodes on one bus
- Jumper for CAN-bus termination 120Ω
- Hex-encoding switches for setting node-ID and baud rate
- CAN-bus baud rate: 10kBit/s to 1Mbit/s
- High-quality connectors included in scope of delivery:
 - Power-Supply:* 2-pin plug connector
 - CAN-bus:* 5-pin plug connector
 - I/O:* single 24-pin plug connector, lockable
- Non-volatile memory for storage of configuration data
- Internal monitoring and diagnostics of:
 - onboard temperature,*
 - power supply,*
 - memory and other controller internals*
- Emergency Messages sent out in case of failure

Power Supply, Environmental Conditions:

- Operating voltage: 24V ±20%
- Current consumption: <70mA
- Operating temperature: -20°C to +70°C
- Storage temperature: -20°C to +90°C
- Dimensions (LxWxH in mm): 95x70x58
- Installation method: DIN-rail mounting
- Enclosure protection class: IP20
- Weight: ca. 130g

Delivery contents / order number

Assembled and tested module,
Manual and corresponding EDS-file.

Order number:
3001004 CANopen IO-X5,
standard version

Device pinout

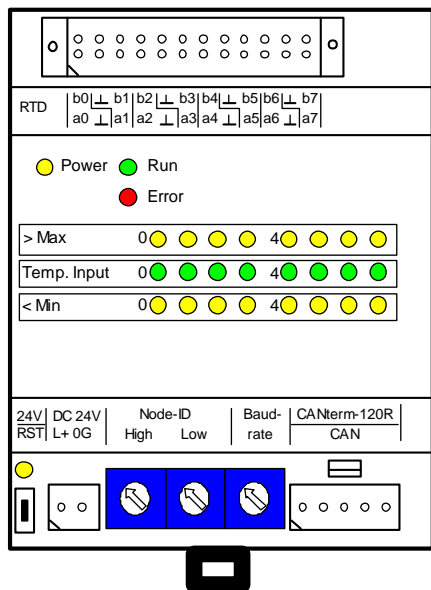

Hex-encoding Switches:

Node ID:

Allows for configuration of node ID from 0x1 ... 0x7F (1..127 dec).
When node-ID is set to value 0xFF, the device is reset to factory settings after power-on or reset.
The node-ID is also configurable via LSS.

Baud rate:

Selectable via Hex-switch:
0 = 1 Mbit/s
1 = 800 kbit/s
2 = 500 kbit/s
3 = 250 kbit/s
4 = 125 kbit/s
5 = 100 kbit/s
6 = 50 kbit/s
7 = 20 kbit/s
8 = 10 kbit/s

The baud rate is also configurable via LSS.

PDO Mapping

In standard configuration (factory settings) the analog inputs AI0..7 are mapped to the following PDO's.

	ID	Length	BYTE 0	BYTE 1	BYTE 2	BYTE 3	BYTE 4	BYTE 5
1. TPDO	180H +Node ID	6	AI PV0 7130H/1	AI0 State 6150H/1	AI PV1 7130H/2	AI1 State 6150H/2		
2. TPDO	280H +Node ID	6	AI PV2 7130H/3	AI2 State 6150H/3	AI PV3 7130H/4	AI3 State 6150H/4		
3. TPDO	380H +Node ID	6	AI PV4 7130H/5	AI4 State 6150H/5	AI PV5 7130H/6	AI5 State 6150H/6		
4. TPDO	480H +Node ID	6	AI PV6 7130H/7	AI6 State 6150H/7	AI PV7 7130H/8	AI7 State 6150H/8		

The PDO-mapping and linking can be changed dynamically by use of a standard CANopen configuration tool. The configuration can be saved to non-volatile memory and thus is available after restart.

Connector pinout:

Pin	Name	Description
Power Connector		
1*	L+	+24VDC ±20%
2	0G	Ground 0
CAN Connector		
1*		CAN ground
2		CAN low
3		n.c.
4		CAN high
5		+24VDC (optional used)
IO Connector		
1*	0a	ch0 I1
2	0b	ch0 I2
3	GND	ch0 Ground
5	1a	ch1 I1
6	1b	ch1 I2
4	GND	ch1 Ground
7	2a	ch2 I1
8	2b	ch2 I2
9	GND	ch2 Ground
11	3a	ch3 I1
12	3b	ch3 I2
10	GND	ch3 Ground
13	4a	ch4 I1
14	4b	ch4 I2
15	GND	ch4 Ground
17	5a	ch5 I1
18	5b	ch5 I2
16	GND	ch5 Ground
19	6a	ch6 I1
20	6b	ch6 I2
21	GND	ch6 Ground
23	7a	ch7 I1
24	7b	ch7 I2
22	GND	ch7 Ground

* in picture pin 1 is marked with slash

Object Dictionary

Index	Object	Name	Data type	Object is mappable	Object gets saved via 1010H	Object gets Restored via 1011H
1000H	Var	Device type	Unsigned32	-	-	-
1001H	Var	Error register	Unsigned8	-	-	-
1003H	Array	Pre-defined error field	Unsigned32	-	-	-
1005H	Var	COB-ID SYNC message	Unsigned32	-	x	x
1007H	Var	Synchronous window length	Unsigned32	-	x	x
1008H	Var	Manufacturer device name	String	-	-	-
1009H	Var	Manufacturer hardware version	String	-	-	-
100AH	Var	Manufacturer software version	String	-	-	-
100CH	Var	Guard Time	Unsigned16	-	x	x
100DH	Var	Life Time Factor	Unsigned8	-	x	x
1010H	Array	Store parameters	Unsigned32	-	-	-
1011H	Array	Restore default parameters	Unsigned32	-	-	-
1014H	Var	COB-ID EMCY	Unsigned32	-	x	x
1017H	Var	Producer Heartbeat Time	Unsigned16	-	x	x
1018H	Record	Identity object	Identity	-	-	-
1029H	Array	Error behavior object	Unsigned8	-	x	x
1200H	Record	1st SDO Server Parameter	SDO Parameter	-	-	-
1400H	Record	RPDO1 Communication parameter	PDOComPar	-	x	x
1401H	Record	RPDO2 Communication parameter	PDOComPar	-	x	x
1600H	Record	RPDO1 Mapping parameter	PDOMapPar	-	x	x
1601H	Record	RPDO2 Mapping parameter	PDOMapPar	-	x	x
2000H	Var	NMT Boot Configuration	Unsigned8	-	-	-
2001H	Array	Device Features	Integer16	-	-	-
2500H	Record	for production only		-	-	-
6110H	Array	AI Sensor Typ	Unsigned16	-	x	x
6112H	Array	AI Operation mode	Unsigned8	-	x	x
6126H	Array	AI Scaling Factor	Real32	-	x	x
6127H	Array	AI Scaling Offset	Real32	-	x	x
6131H	Array	AI Physical Unit PV	Unsigned32	-	x	x
6132H	Array	AI Decimal Digits PV	Unsigned8	-	x	x
6150H	Array	AI Status	Unsigned8	x	-	-
7100H	Array	AI Input FV	Integer16	x	-	-
7130H	Array	AI Input PV	Integer16	x	-	-
7133H	Array	AI Interrupt delta input PV	Integer16	-	x	x
7134H	Array	AI interrupt lower limit input PV	Integer16	-	x	x
7135H	Array	AI interrupt upper limit input PV	Integer16	-	x	x

IO circuitry

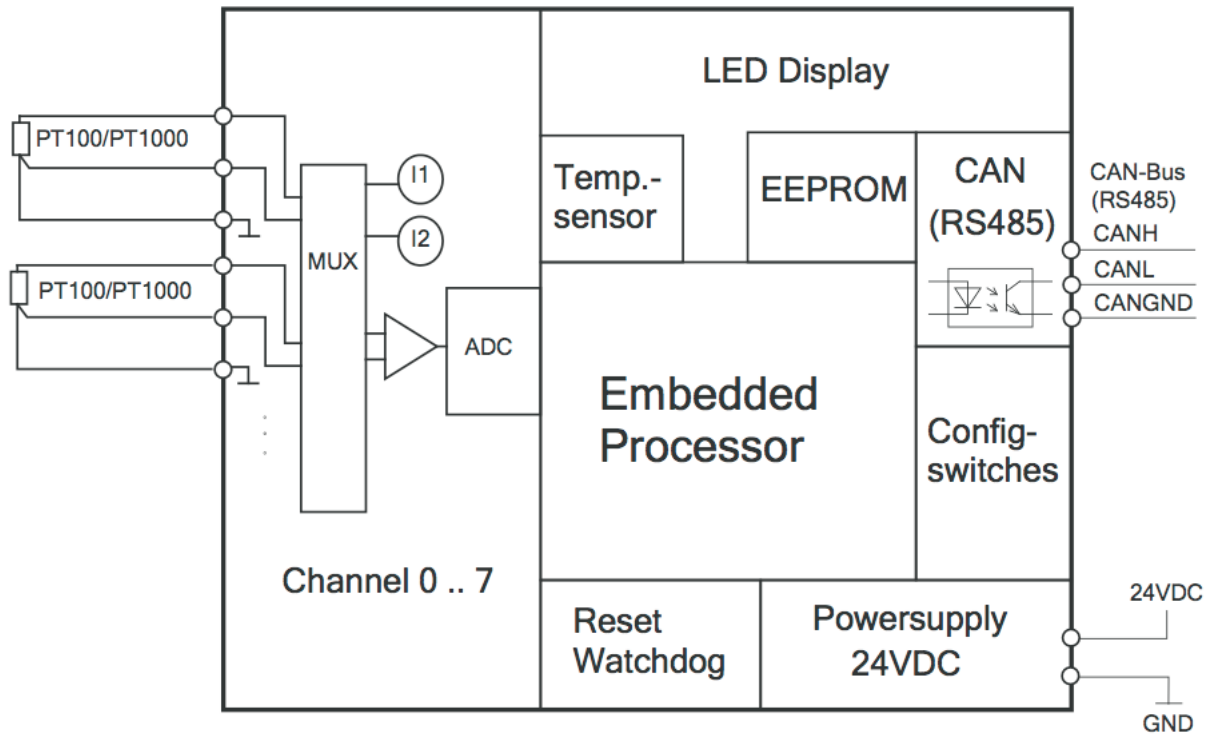

Device dimensions

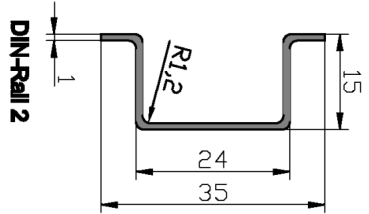
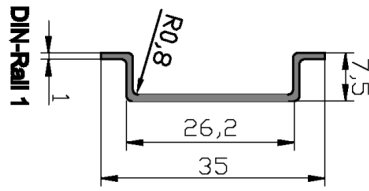
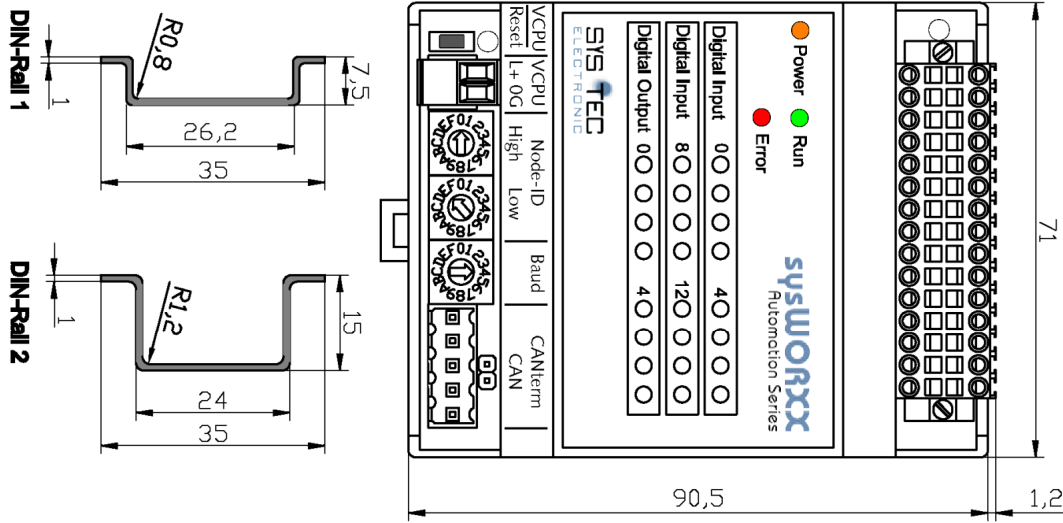

With DIN-Rail 1

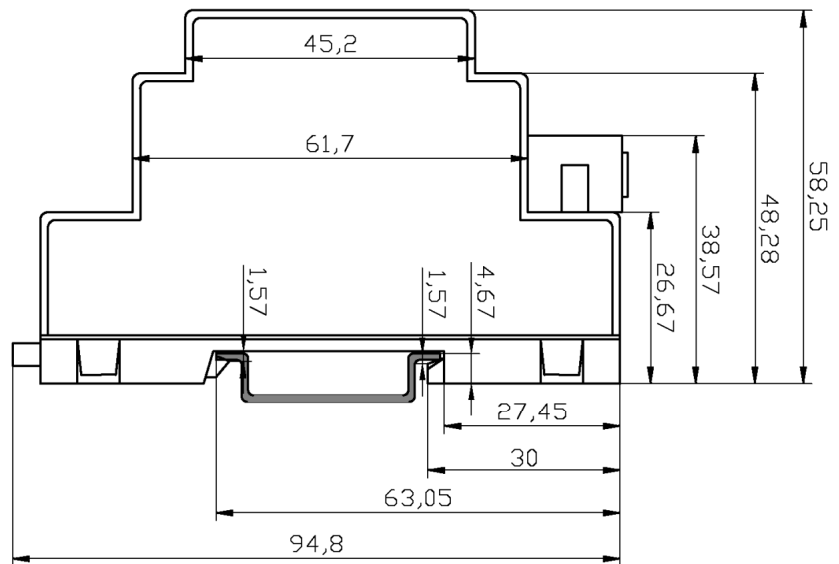

With DIN-Rail 2

