

CANopen IO-X3 – Fact sheet

Overview

The CANopen IO-X3 is a very compact and cost effective CANopen IO module featuring a high-density of industrial proven IO's.

The module includes a CPU-core including the pre-programmed firmware for CANopen communication and peripherals for the industrial inputs and outputs. Extensive diagnostic routines are implemented to ensure a most reliable and safe operation.

All inputs and outputs as well as configuration parameters are accessible via the CANopen protocol.

The CANopen IO-X3 is a CANopen slave device according CANopen device profile **CiA 401 DS V2.1** and CANopen communication profile **CiA 301 DS V4.02**.

Two LED indicate the device state according to **CiA 303-3 DR V1.0**.

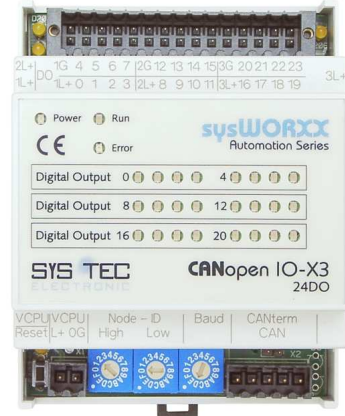

IO configuration:

- Digital outputs:
24 channels
24VDC / 500mA
high side switches
short circuit protection (max. 4A) and monitoring
overheat protection

CANopen features:

- Communication profile CiA 301 DS V4.02
- Device profile CiA 401 DS V1.2
- State indicator profile CiA 303-3 DR V1.0
- Layer Setting Service (LSS)
CiA 305 DS V1.1
- 2 RPDO
- Dynamic PDO-Linking and -Mapping
- SDO-Server
- Life guarding, Node guarding, Heartbeat Producer
- 5 Heartbeat Consumers
- Emergency Producer
- Minimum Boot-up capability (Slave)
- Minimum NMT boot-up master (Manufacturer extension)

Communication and device configuration:

- Galvanic decoupled CAN-bus driver supports up to 110 CAN-nodes on one bus
- Jumper for CAN-bus termination 120Ω
- Hex-encoding switches for setting node-ID and baud rate
- CAN-bus baud rate: 10kBit/s to 1Mbit/s
- High-quality connectors included in scope of delivery:
Power-Supply: 2-pin plug connector
CAN-bus: 5-pin plug connector
I/O: single 30-pin plug connector, lockable
- Non-volatile memory for storage of configuration data
- Internal monitoring and diagnostics of:
onboard temperature,
power supply,
memory and other controller internals
- Emergency Messages sent out in case of failure

Power Supply, Environmental Conditions:

- Operating voltage: 24V ±20%
- Current consumption: <70mA
- Operating temperature: -20°C to +70°C
- Storage temperature: -20°C to +90°C
- Dimensions (LxWxH in mm): 95x70x58
- Installation method: DIN-rail mounting
- Enclosure protection class: IP20
- Weight: ca. 130g

Delivery contents / order number

Assembled and tested module,
Manual and corresponding EDS-file.

Order number:
3001002 CANopen IO-X3,
standard version

Device pinout

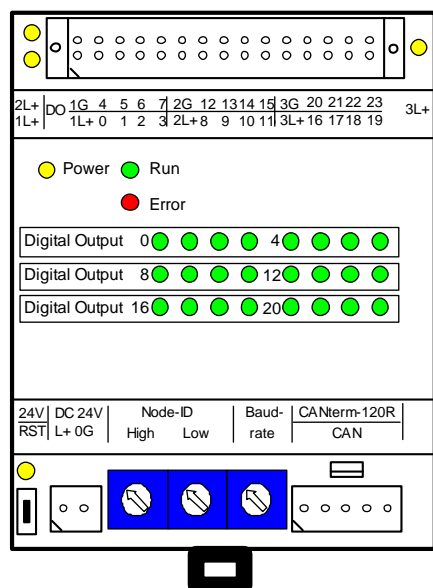

Connector pinout:

Pin	Name	Description
Power Connector		
1*	L+	+24VDC ±20%
2	0G	Ground 0
CAN Connector		
1*		CAN ground
2		CAN low
3		n.c.
4		CAN high
5		+24VDC (optional used)
IO Connector		
1*	L+	Group 1 +24V supply
2	1G	Group 1 Ground
3	0	Group 1 digital output 0
5	1	Group 1 digital output 1
7	2	Group 1 digital output 2
9	3	Group 1 digital output 3
4	4	Group 1 digital output 4
6	5	Group 1 digital output 5
8	6	Group 1 digital output 6
10	7	Group 1 digital output 7
11	2L+	Group 2 +24V supply
12	2G	Group 2 Ground
13	8	Group 2 digital output 8
15	9	Group 2 digital output 9
17	10	Group 2 digital output 10
19	11	Group 2 digital output 11
14	12	Group 2 digital output 12
16	13	Group 2 digital output 13
18	14	Group 2 digital output 14
20	15	Group 2 digital output 15
21	3L+	Group 3 +24V supply
22	3G	Group 3 Ground
23	16	Group 3 digital output 16
25	17	Group 3 digital output 17
27	18	Group 3 digital output 18
29	19	Group 3 digital output 19
24	20	Group 3 digital output 20
26	21	Group 3 digital output 21
28	22	Group 3 digital output 22
30	23	Group 3 digital output 23

* in picture pin 1 is marked with slash

Hex-encoding Switches:

Node ID:

Allows for configuration of node ID from 0x1 ... 0x7F (1..127 dec).
When node-ID is set to value 0xFF, the device is reset to factory settings after power-on or reset.
The node-ID is also configurable via LSS.

Baud rate:

Selectable via Hex-switch:
0 = 1 Mbit/s
1 = 800 kbit/s
2 = 500 kbit/s
3 = 250 kbit/s
4 = 125 kbit/s
5 = 100 kbit/s
6 = 50 kbit/s
7 = 20 kbit/s
8 = 10 kbit/s

The baud rate is also configurable via LSS.

PDO Mapping

In standard configuration (factory settings) the digital outputs DO0..23 are mapped as shown in the table below.

	ID	Length	BYTE 0	BYTE 1	BYTE 2
1. RPDO	200H +Node ID	3	DO0_7 6200H/1	DO8_15 6200H/2	DO16_23 6200H/3

The PDO-mapping and linking can be changed dynamically by use of a standard CANopen configuration tool. The configuration can be saved to non-volatile memory and thus is available after restart.

Object Dictionary

Index	Object	Name	Data type	Object is mappable	Object gets saved via 1010H	Object gets Restored via 1011H
1000H	Var	Device type	Unsigned32	-	-	-
1001H	Var	Error register	Unsigned8	-	-	-
1003H	Array	Pre-defined error field	Unsigned32	-	-	-
1005H	Var	COB-ID SYNC message	Unsigned32	-	x	x
1007H	Var	Synchronous window length	Unsigned32	-	x	x
1008H	Var	Manufacturer device name	String	-	-	-
1009H	Var	Manufacturer hardware version	String	-	-	-
100AH	Var	Manufacturer software version	String	-	-	-
100CH	Var	Guard Time	Unsigned16	-	x	x
100DH	Var	Life Time Factor	Unsigned8	-	x	x
1010H	Array	Store parameters	Unsigned32	-	-	-
1011H	Array	Restore default parameters	Unsigned32	-	-	-
1014H	Var	COB-ID EMCY	Unsigned32	-	x	x
1016H	Array	Consumer Heartbeat Time	Unsigned32	-	x	x
1017H	Var	Producer Heartbeat Time	Unsigned16	-	x	x
1018H	Record	Identity object	Identity	-	-	-
1029H	Array	Error behavior object	Unsigned8	-	x	x
1200H	Record	1st SDO Server Parameter	SDO Parameter	-	-	-
1400H	Record	RPDO1 Communication parameter	PDOComPar	-	x	x
1401H	Record	RPDO2 Communication parameter	PDOComPar	-	x	x
1600H	Record	RPDO1 Mapping parameter	PDOMapPar	-	x	x
1601H	Record	RPDO2 Mapping parameter	PDOMapPar	-	x	x
2000H	Var	NMT Boot Configuration	Unsigned8	-	-	-
2001H	Array	Device Features	Integer16	-	-	-
2500H	Record	for Production only	Production	-	-	-
6200H	Array	Write Output 8Bit	Unsigned8	x	-	-
6206H	Array	Error Mode Output 8Bit	Unsigned8	-	x	x
6207H	Array	Error Value Output 8Bit	Unsigned8	-	x	x
6208H	Array	Filter Mask Output 8Bit	Unsigned8	-	x	x

IO circuitry

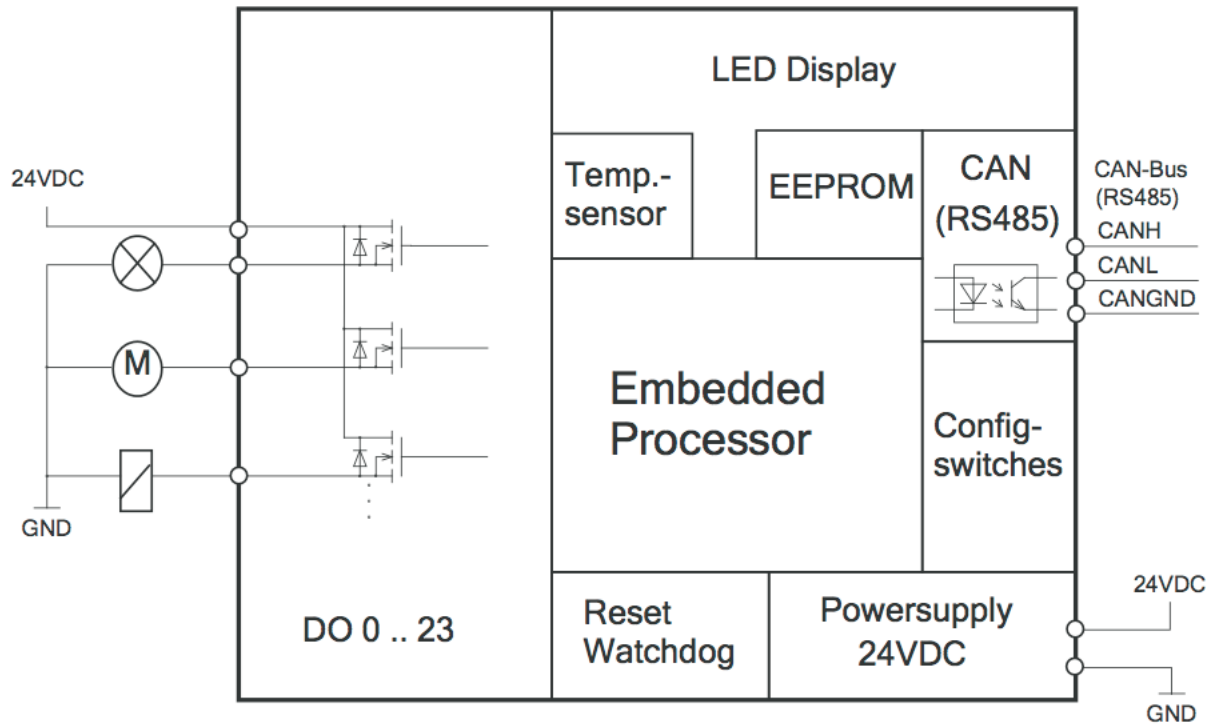

Device dimensions

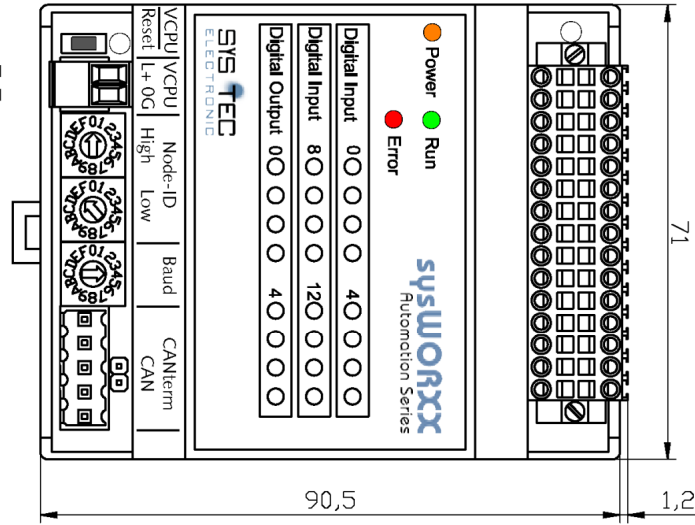
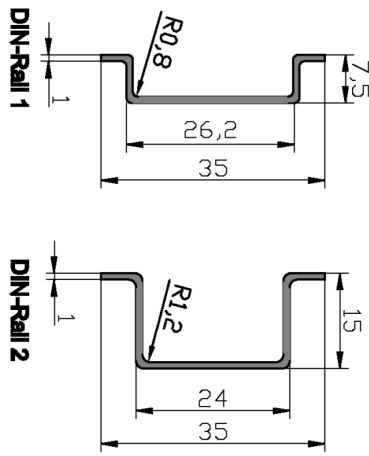

With DIN-Rail 1

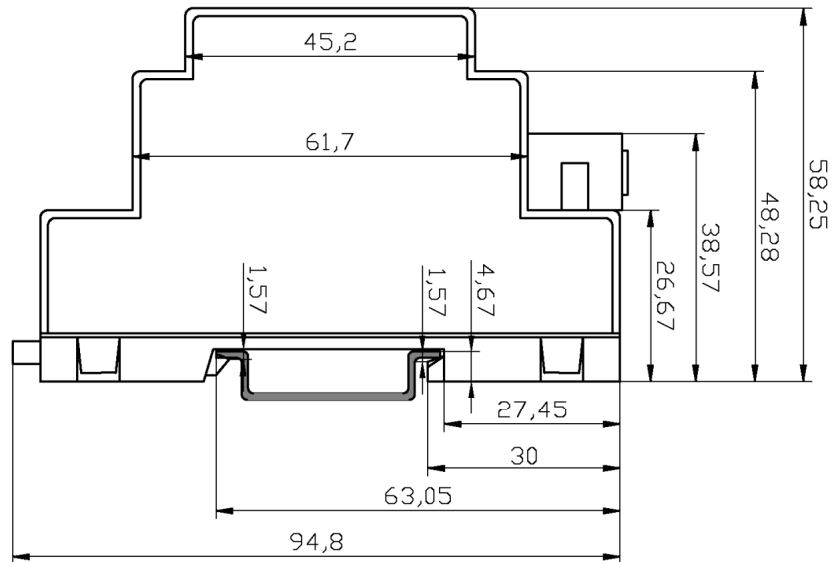

With DIN-Rail 2

