

## CANopen IO-X2 – Fact sheet

### Overview

The CANopen IO-X2 is a very compact and cost effective CANopen IO module featuring a high-density of industrial proven I/O's.

The module includes a CPU-core including the pre-programmed firmware for CANopen communication and peripherals for the industrial inputs and outputs. Extensive diagnostic routines are implemented to ensure a most reliable and safe operation.

All inputs and outputs as well as configuration parameters are accessible via the CANopen protocol.

The CANopen IO-X2 is a CANopen slave device according CANopen device profile **CiA 401 DS V2.1** and CANopen communication profile **CiA 301 DS V4.02**.

Two LED indicate the device state according to **CiA 303-3 DR V1.0**.

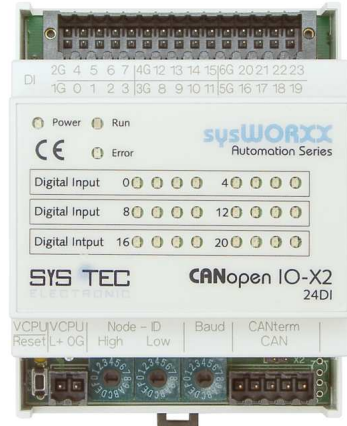

### IO configuration:

- Digital inputs:  
24 channels  
24VDC  
galvanic isolated  
4 channels share one common ground

### CANopen features:

- Communication profile CiA 301 DS V4.02
- Device profile CiA 401 DS V2.1
- State indicator profile CiA 303-3 DR V1.0
- Layer Setting Service (LSS)  
CiA 305 DS V1.1
- 2 TPDO
- Dynamic PDO-Linking and -Mapping
- SDO-Server
- Life guarding, Node guarding, Heartbeat  
Producer
- Emergency Producer
- Minimum Boot-up capability (Slave)
- Minimum NMT boot-up master (Manufacturer  
extension)

### Communication and device configuration:

- Galvanic decoupled CAN-bus driver supports  
up to 110 CAN-nodes on one bus
- Jumper for CAN-bus termination 120Ω
- Hex-encoding switches for setting node-ID  
and baud rate
- CAN-bus baud rate: 10kBit/s to 1Mbit/s
- High-quality connectors included in scope of  
delivery:  
*Power-Supply:* 2-pin plug connector  
*CAN-bus:* 5-pin plug connector  
*I/O:* single 30-pin plug connector, lockable
- Non-volatile memory for storage of  
configuration data
- Internal monitoring and diagnostics of:  
*onboard temperature,*  
*power supply,*  
*memory and other controller internals*
- Emergency Messages sent out in case of  
failure

### Power Supply, Environmental Conditions :

- Operating voltage: 24V ±20%
- Current consumption: <70mA
- Operating temperature: -20°C to +70°C
- Storage temperature: -20°C to +90°C
- Dimensions (LxWxH in mm): 95x70x58
- Installation method: DIN-rail mounting
- Enclosure protection class: IP20
- Weight: ca. 130g

### Delivery contents / order number

Assembled and tested module,  
Manual and corresponding EDS-file.

Order number:  
30010001      CANopen IO-X2,  
standard version

**Device pinout**

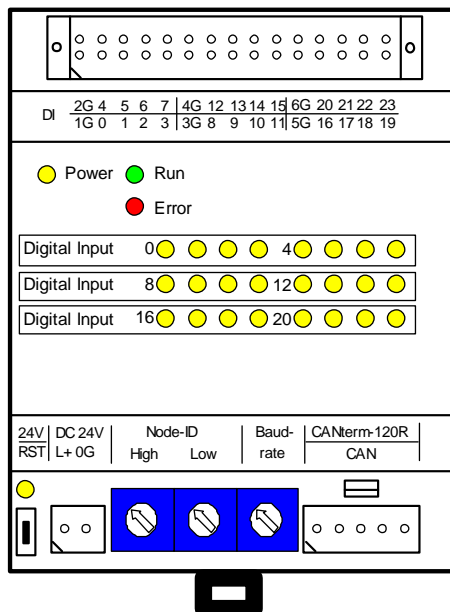

**Hex-encoding Switches:**

Node ID:

Allows for configuration of node ID from 0x1 ... 0x7F (1..127 dec).  
When node-ID is set to value 0xFF, the device is reset to factory settings after power-on or reset.  
The node-ID is also configurable via LSS.

Baud rate:

Selectable via Hex-switch:  
0 = 1 Mbit/s  
1 = 800 kbit/s  
2 = 500 kbit/s  
3 = 250 kbit/s  
4 = 125 kbit/s  
5 = 100 kbit/s  
6 = 50 kbit/s  
7 = 20 kbit/s  
8 = 10 kbit/s

The baud rate is also configurable via LSS.

**PDO Mapping**

In standard configuration (factory settings) the digital inputs DI0..23 are mapped as shown in the table below.

	ID	Length	BYTE 0	BYTE 1	BYTE 2
1. TPDO	180H +Node ID	3	DI0_7 6000H/1	DI8_15 6000H/2	DI16_23 6000H/3

The PDO-mapping and linking can be changed dynamically by use of a standard CANopen configuration tool. The configuration can be saved to non-volatile memory and thus is available after restart.

**Connector pinout:**

Pin	Name	Description
<b>Power Connector</b>		
1*	L+	+24VDC ±20%
2	0G	Ground 0
<b>CAN Connector</b>		
1*		CAN ground
2		CAN low
3		n.c.
4		CAN high
5		+24VDC (optional used)
<b>IO Connector</b>		
1*	1G	Ground 1
3	0	digital input 0 24V to 1G
5	1	digital input 1 24V to 1G
7	2	digital input 2 24V to 1G
9	3	digital input 3 24V to 1G
2	2G	Ground 2
4	4	digital input 4 24V to 2G
6	5	digital input 5 24V to 2G
8	6	digital input 6 24V to 2G
10	7	digital input 7 24V to 2G
11	3G	Ground 3
13	8	digital input 8 24V to 3G
15	9	digital input 9 24V to 3G
17	10	digital input 10 24V to 3G
19	11	digital input 11 24V to 3G
12	4G	Ground 4
14	12	digital input 12 24V to 4G
16	13	digital input 13 24V to 4G
18	14	digital input 14 24V to 4G
20	15	digital input 15 24V to 4G
21	5G	Ground 5
23	16	digital input 16 24V to 5G
25	17	digital input 17 24V to 5G
27	18	digital input 18 24V to 5G
29	19	digital input 19 24V to 5G
22	6G	Ground 6
24	20	digital input 20 24V to 6G
26	21	digital input 21 24V to 6G
28	22	digital input 22 24V to 6G
30	23	digital input 23 24V to 6G

\* in picture pin 1 is marked with slash

**Object Dictionary**

Index	Object	Name	Data type	Object is mappable	Object gets saved via 1010H	Object gets Restored via 1011H
1000H	Var	Device type	Unsigned32	-	-	-
1001H	Var	Error register	Unsigned8	-	-	-
1003H	Array	Pre-defined error field	Unsigned32	-	-	-
1005H	Var	COB-ID SYNC message	Unsigned32	-	x	x
1007H	Var	Synchronous window length	Unsigned32	-	x	x
1008H	Var	Manufacturer device name	String	-	-	-
1009H	Var	Manufacturer hardware version	String	-	-	-
100AH	Var	Manufacturer software version	String	-	-	-
100CH	Var	Guard Time	Unsigned16	-	x	x
100DH	Var	Life Time Factor	Unsigned8	-	x	x
1010H	Array	Store parameters	Unsigned32	-	-	-
1011H	Array	Restore default parameters	Unsigned32	-	-	-
1014H	Var	COB-ID EMCY	Unsigned32	-	x	x
1017H	Var	Producer Heartbeat Time	Unsigned16	-	x	x
1018H	Record	Identity object	Identity	-	-	-
1029H	Array	Error behavior object	Unsigned8	-	x	x
1200H	Record	1st SDO Server Parameter	SDO Parameter	-	-	-
1800H	Record	TPDO1 Communication parameter	PDOComPar	-	x	x
1801H	Record	TPDO2 Communication parameter	PDOComPar	-	x	x
1A00H	Record	TPDO1 Mapping parameter	PDOMapPar	-	x	x
1A01H	Record	TPDO2 Mapping parameter	PDOMapPar	-	x	x
2000H	Var	NMT Boot Configuration	Unsigned8	-	-	-
2001H	Array	Device Features	Integer16	-	-	-
2010H	Array	Disable digital input 8 bit	Unsigned8	-	x	x
2500H	Record	for Production only	Production	-	-	-
6000H	Array	Read Digital Input 8Bit	Unsigned8	x	-	-
6003H	Array	Filter Constant Input 8Bit	Unsigned8	-	x	x
6005H	Var	Global Interrupt Enable 8Bit	Boolean	-	-	-
6006H	Array	Interrupt Mask Any Change 8Bit	Unsigned8	-	x	x
6007H	Array	Interrupt Mask Low to High 8Bit	Unsigned8	-	x	x
6008H	Array	Interrupt Mask High to Low8Bit	Unsigned8	-	x	x

**IO circuitry**

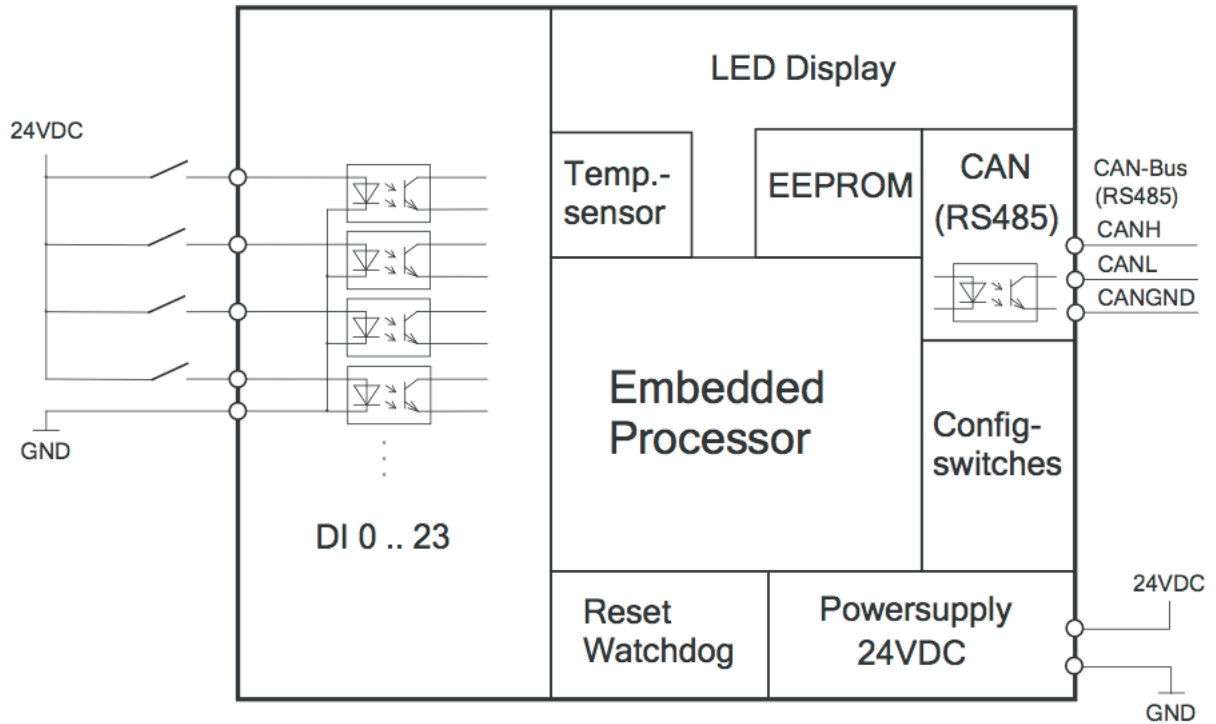

**Device dimensions**

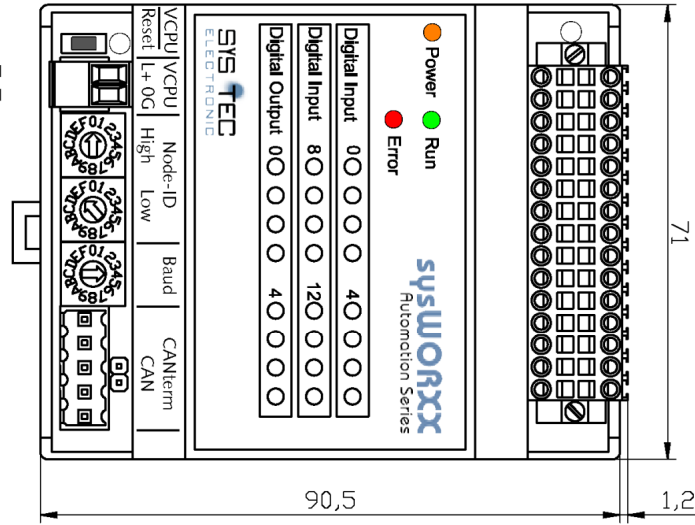
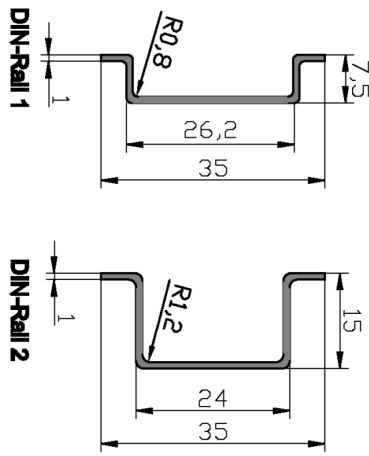

**With DIN-Rail 1**

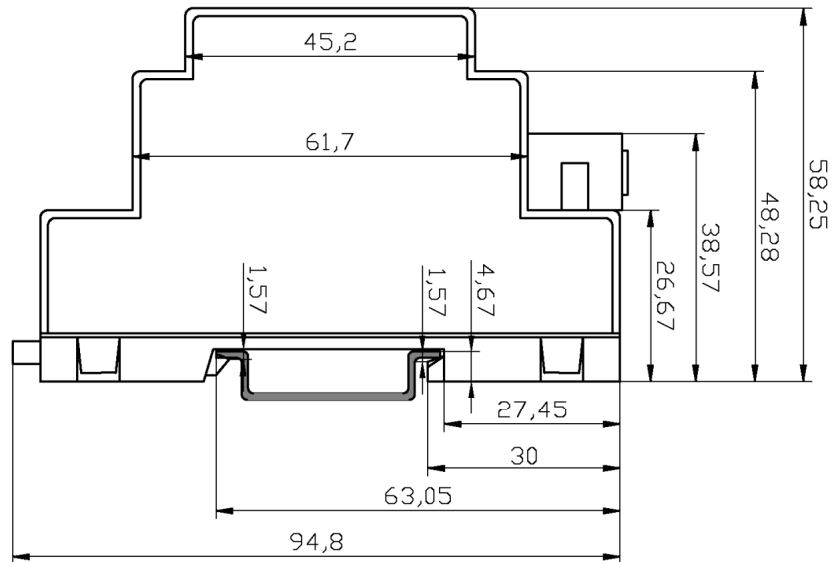

**With DIN-Rail 2**

