

## CANopen IO-X1 – Fact sheet

### Overview

The CANopen IO-X1 is a very compact and cost effective CANopen IO module featuring a high-density of industrial proven I/O's.

The module includes a CPU-core including the pre-programmed firmware for CANopen communication and peripherals for the industrial inputs and outputs. Extensive diagnostic routines are implemented to ensure a most reliable and safe operation.

All inputs and outputs as well as configuration parameters are accessible via the CANopen protocol.

The CANopen IO-X1 is a CANopen slave device according CANopen device profile **CiA 401 DS V2.1** and CANopen communication profile **CiA 301 DS V4.02**.

Two LED indicate the device state according to **CiA 303-3 DR V1.0**.

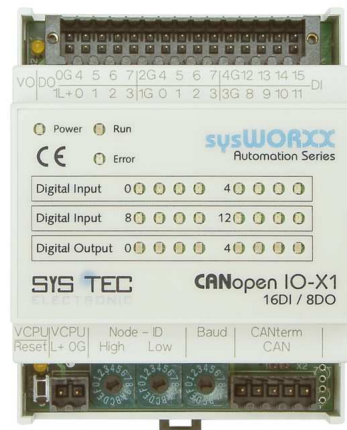

### IO configuration:

- Digital outputs:  
8 channels, 24VDC / 500mA high side switches with short circuit protection and monitoring, overheat protection
- Digital inputs:  
16 channels, 24VDC galvanic isolated  
4 channels share same ground

### CANopen features:

- Communication profile CiA 301 DS V4.02
- Device profile CiA 401 DS V2.1
- State indicator profile CiA 303-3 DR V1.0
- Layer Setting Service (LSS) CiA 305 DS V1.1
- 2 TPDO and 2 RPDO
- Dynamic PDO-Linking and -Mapping
- SDO-Server
- Life guarding, Node guarding, Heartbeat Producer
- 5 Heartbeat Consumers
- Emergency Producer
- Minimum Boot-up capability (Slave)
- Minimum NMT boot-up master function (Manufacturer extension)

### Communication and device configuration:

- Galvanic decoupled CAN-bus driver supports up to 110 CAN-nodes on one bus
- Jumper for CAN-bus termination 120Ω
- Hex-encoding switches for setting node-ID and baud rate
- CAN-bus baud rate: 10kBit/s to 1Mbit/s
- High-quality connector included in scope of delivery:  
*Power-Supply: 2-pin plug connector*  
*CAN-bus: 5-pin plug connector*  
*I/O: single 30-pin plug connector, lockable*
- Non-volatile memory for storage of configuration data
- Internal monitoring and diagnostics of:  
*onboard temperature,*  
*power supply,*  
*memory and other controller internals*
- Emergency Messages sent out in case of failure

### Power Supply, Environmental Conditions:

- Operating voltage: 24V ±20%
- Current consumption: < 70mA
- Operating temperature: -20°C to +70°C
- Storage temperature: -20°C to +90°C
- Dimensions (LxWxH in mm): 95x70x58
- Installation method: DIN-rail mounting
- Enclosure protection class: IP20
- Weight: ca. 130g

### Delivery contents / order number

Assembled and tested module,  
Manual and corresponding EDS-file.

Order number:	
3001000	CANopen IO-X1, standard version
3001010	CANopen IO-X1, pulsed output

**Device pinout**

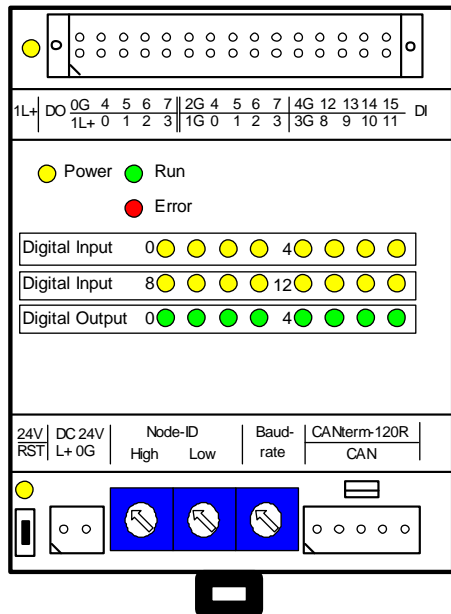

**Hex-encoding Switches:**

Node ID:

Allows for configuration of node ID from 0x1 ... 0x7F (1..127 dec).  
When node-ID is set to value 0xFF, the device is reset to factory settings after power-on or reset.  
The node-ID is also configurable via LSS.

Baud rate:

Selectable via Hex-switch:  
0 = 1 Mbit/s  
1 = 800 kbit/s  
2 = 500 kbit/s  
3 = 250 kbit/s  
4 = 125 kbit/s  
5 = 100 kbit/s  
6 = 50 kbit/s  
7 = 20 kbit/s  
8 = 10 kbit/s

The baud rate is also configurable via LSS.

**PDO Mapping**

In standard configuration (factory settings) the digital output DO0..7 and the digital inputs DI0..15 are mapped to the following PDO's.

	ID	Length	BYTE 0	BYTE 1
1. RPDO	200H +Node ID	1	DO0_7 6200H/1	
1. TPDO	180H +Node ID	2	DI0_7 6000H/1	DI8_15 6000H/2

The PDO-mapping and linking can be changed dynamically by use of a standard CANopen configuration tool. By doing so, the 2nd TPDO and 2nd RPDO become available. The configuration can be saved to non-volatile memory and thus is available after restart.

**Connector pinout:**

Pin	Name	Description
<b>Power Connector</b>		
1*	L+	+24VDC ±20%
2	0G	Ground 0
<b>CAN Connector</b>		
1*		CAN ground
2		CAN low
3		n.c.
4		CAN high
5		+24VDC (optional used)
<b>IO Connector</b>		
1*	1L+	+24VDC ( connected to L+ )
2	0G	Ground 0 for digital outputs
3	0	digital output 0 24V/500mA
4	4	digital output 4 24V/500mA
5	1	digital output 1 24V/500mA
6	5	digital output 5 24V/500mA
7	2	digital output 2 24V/500mA
8	6	digital output 6 24V/500mA
9	3	digital output 3 24V/500mA
10	7	digital output 7 24V/500mA
11	1G	Ground 1
13	0	digital input 0 24V to 1G
15	1	digital input 1 24V to 1G
17	2	digital input 2 24V to 1G
19	3	digital input 3 24V to 1G
12	2G	Ground 2
14	4	digital input 4 24V to 2G
16	5	digital input 5 24V to 2G
18	6	digital input 6 24V to 2G
20	7	digital input 7 24V to 2G
21	3G	Ground 3
23	8	digital input 8 24V to 3G
25	9	digital input 9 24V to 3G
27	10	digital input 10 24V to 3G
29	11	digital input 11 24V to 3G
22	4G	Ground 4
24	12	digital input 12 24V to 4G
26	13	digital input 13 24V to 4G
28	14	digital input 14 24V to 4G
30	15	digital input 15 24V to 4G

\* in picture pin 1 is marked with slash

**Object Dictionary**

Index	Object	Name	Data type	Object is mappable	Object gets saved via 1010H	Object gets Restored via 1011H
1000H	Var	Device type	Unsigned32	-	-	-
1001H	Var	Error register	Unsigned8	-	-	-
1003H	Array	Pre-defined error field	Unsigned32	-	-	-
1005H	Var	COB-ID SYNC message	Unsigned32	-	x	x
1007H	Var	Synchronous window length	Unsigned32	-	x	x
1008H	Var	Manufacturer device name	String	-	-	-
1009H	Var	Manufacturer hardware version	String	-	-	-
100AH	Var	Manufacturer software version	String	-	-	-
100CH	Var	Guard Time	Unsigned16	-	x	x
100DH	Var	Life Time Factor	Unsigned8	-	x	x
1010H	Array	Store parameters	Unsigned32	-	-	-
1011H	Array	Restore default parameters	Unsigned32	-	-	-
1014H	Var	COB-ID EMCY	Unsigned32	-	x	x
1016H	Array	Consumer Heartbeat Time	Unsigned32	-	x	x
1017H	Var	Producer Heartbeat Time	Unsigned16	-	x	x
1018H	Record	Identity object	Identity	-	-	-
1029H	Array	Error behavior object	Unsigned8	-	x	x
1200H	Record	1st SDO Server Parameter	SDO Parameter	-	-	-
1400H	Record	RPDO1 Communication parameter	PDOComPar	-	x	x
1401H	Record	RPDO2 Communication parameter	PDOComPar	-	x	x
1600H	Record	RPDO1 Mapping parameter	PDOMapPar	-	x	x
1601H	Record	RPDO2 Mapping parameter	PDOMapPar	-	x	x
1800H	Record	TPDO1 Communication parameter	PDOComPar	-	x	x
1801H	Record	TPDO2 Communication parameter	PDOComPar	-	x	x
1A00H	Record	TPDO1 Mapping parameter	PDOMapPar	-	x	x
1A01H	Record	TPDO2 Mapping parameter	PDOMapPar	-	x	x
2000H	Var	NMT Boot Configuration	Unsigned8	-	-	-
2001H	Array	Device Features	Integer16	-	-	-
2010H	Array	Disable digital input 8 bit	Unsigned8	-	x	x
2011H	Array	Enable pulsed digital output	Unsigned8	-	x	x
2012H	Array	Enable retrigger pulsed digital output	Unsigned8	-	x	x
2013H	Array	Enable active off pulsed digital output	Unsigned8	-	x	x
2014H	Array	Pulslength pulsed digital output	Unsigned16	-	x	x
2500H	Record	for Production only	Production	-	-	-
6000H	Array	Read Digital Input 8Bit	Unsigned8	x	-	-
6003H	Array	Filter Constant Input 8Bit	Unsigned8	-	x	x
6005H	Var	Global Interrupt Enable 8Bit	Boolean	-	-	-
6006H	Array	Interrupt Mask Any Change 8Bit	Unsigned8	-	x	x
6007H	Array	Interrupt Mask Low to High 8Bit	Unsigned8	-	x	x
6008H	Array	Interrupt Mask High to Low8Bit	Unsigned8	-	x	x
6200H	Array	Write Output 8Bit	Unsigned8	x	-	-
6206H	Array	Error Mode Output 8Bit	Unsigned8	-	x	x
6207H	Array	Error Value Output 8Bit	Unsigned8	-	x	x
6208H	Array	Filter Mask Output 8Bit	Unsigned8	-	x	x

**IO circuitry**

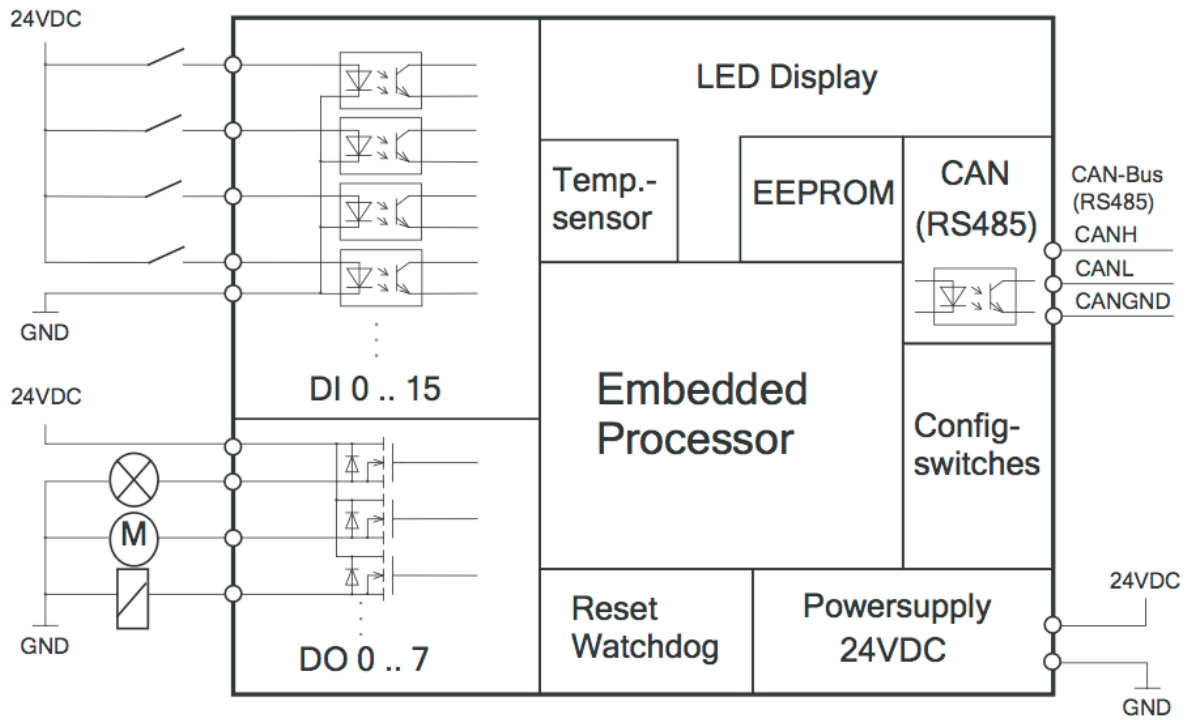

**Device dimensions**

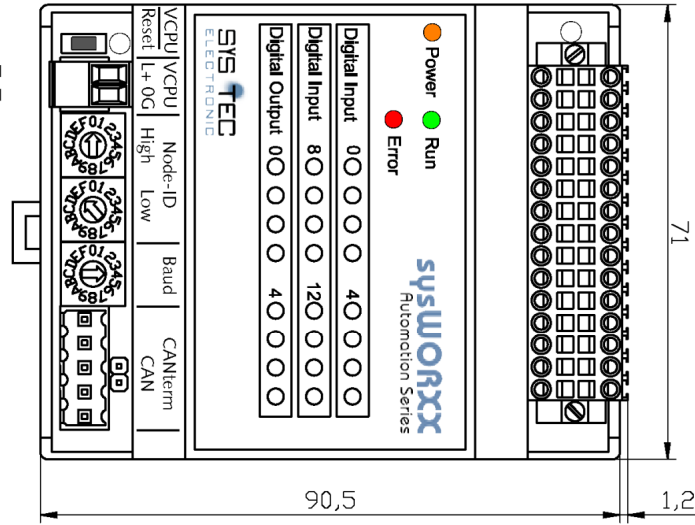
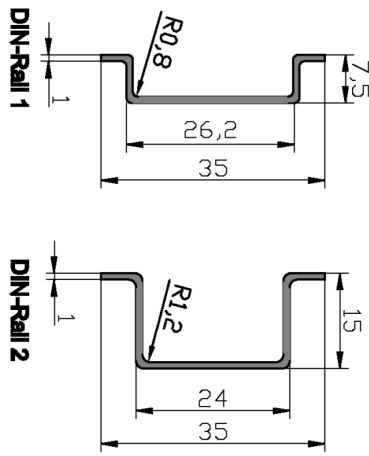

**With DIN-Rail 1**

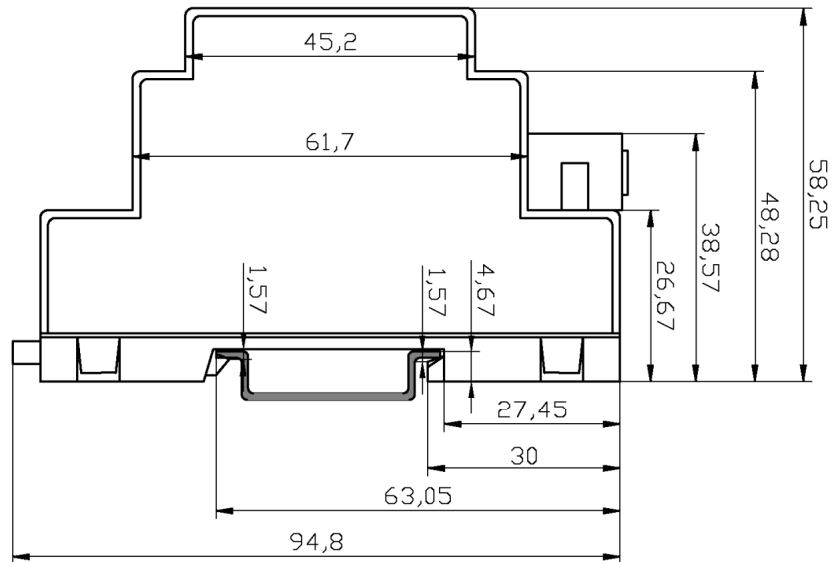

**With DIN-Rail 2**

